



Neo Flex Cantilever UHD



Max screen size: 70"
Max weight 120 lbs – 54.4 kg
CAUTION: DO NOT EXCEED
MAXIMUM LISTED WEIGHT
CAPACITY. SERIOUS INJURY
OR PROPERTY DAMAGE MAY
OCCUR!

OM#	OM110608
-----	----------

CAUTION!
MAXIMUM WEIGHT CAPACITY



CAUTION!
MAXIMUM SCREEN SIZE

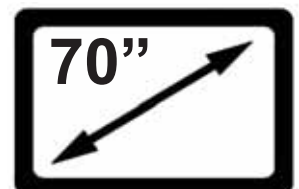

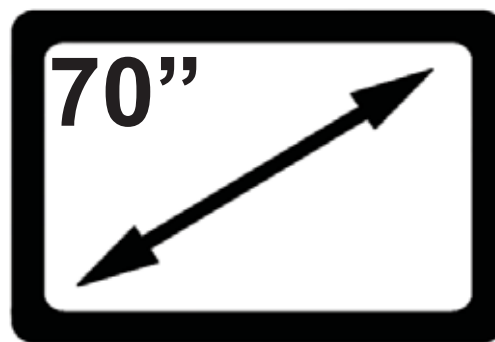
CAUTION!**MAXIMUM WEIGHT CAPACITY****CAUTION!****MAXIMUM SCREEN SIZE**

USE WITH FLAT PANELS EXCEEDING THE MAXIMUM WEIGHT CAPACITY OF THIS PRODUCT MAY RESULT IN PRODUCT FAILURE CAUSING POSSIBLE INJURY AND OR PROPERTY DAMAGE.

EL USO CON TELEVISORES DE PANTALLA PLANA CUYO PESO EXCEDA LA CAPACIDAD MÁXIMA DEL PRODUCTO PUEDE OCASIONAR FALLAS EN ÉSTE Y CAUSAR LESIONES O DAÑOS MATERIALES.

SI VOUS UTILISEZ CE PRODUIT AVEC DES ÉCRANS PLATS DÉPASSANT LA CHARGE MAXIMALE AUTORISÉE, LE PRODUIT POURRAIT MAL FONCTIONNER, ENTRAÎNANT BLESSURES ET ENDOMMAGEMENT DE MATÉRIEL.

DIE BEFESTIGUNG VON FLACHBILDSCHIRMEN, DEREN GEWICHT DIE MAXIMALE BELASTBARKEIT DIESER HALTERUNG ÜBERSCHREITET, KANN ZUR BESCHÄDIGUNG DES PRODUKTS SOWIE ZU VERLETZUNGEN UND/ODER SACHSCHADEN FÜHREN.

GEBRUIK IN COMBINATIE MET VLAKKE SCHERMEN DIE DE MAXIMALE GEWICHTSCAPACITEIT VAN DIT PRODUCT OVERSCHRIJDEN, KAN LEIDEN TOT DEFECTEN AAN HET PRODUCT MET MOGELIJK LETSEL EN/OF SCHADE ALS GEVOLG.

L'USO CON PANNELLI PIATTI CHE ECCEDONO LA PORTATA MASSIMA DEL PRODOTTO PUÒ COMPORTARE IL DANNEGGIAMENTO DEL PRODOTTO, CON LA POSSIBILITÀ DI LESIONI ALLE PERSONE E DANNI ALLE COSE.

UŻYWANIE W POŁĄCZENIU Z TELEWIZORAMI O WADZE PRZEKRACZAJĄCEJ DOPUSZCZALNE OBCIĄŻENIE TEGO PRODUKTU MOŻE SPOWODOWAĆ AWARIĘ PRODUKTU PROWADZĄCĄ DO URAZU CIAŁA LUB USZKODZENIA MIENIA.

POUŽITÍ S PLOCHÝMI OBRAZOVKAMI PŘESAHUJÍCÍMI MAXIMÁLNÍ NOSNOST TOHOTO VÝROBKU MŮŽE ZPŮSOBIT DEFEXT VÝROBKU, KTERÝ BUDE PŘÍČINOU MOŽNÉHO PORANĚNÍ NEBO POŠKOZENÍ MAJETKU.

HA A TERMÉKET A MAXIMÁLIS TERHELHETŐSÉGET MAGHALADÓ LAPOSKÉPERNYŐKKEK HASZNÁLJA, A TERMÉK MŰKÖDÉSE SORÁN HIBA LÉPHET FEL, AMELY SÉRÜLÉST VAGY ANYAGI KÁRT OKOZHAT.

Η ΧΡΗΣΗ ΜΕ ΕΠΙΠΕΔΕΣ ΟΘΟΝΕΣ ΠΟΥ ΥΠΕΡΒΑΙΝΟΥΝ ΤΟΝ ΜΕΓΙΣΤΟ ΑΡΙΘΜΟ ΙΚΑΝΟΤΗΤΑΣ ΒΑΡΟΥΣ ΑΥΤΟΥ ΤΟΥ ΠΡΟΪΟΝΤΟΣ, ΕΝΔΕΧΕΤΑΙ ΝΑ ΠΡΟΚΑΛΕΣΕΙ ΒΛΑΒ ΣΤΟ ΠΡΟΪΟΝ, ΠΙΘΑΝΗ ΣΩΜΑΤΙΚΗ ΒΛΑΒΗ Η ΥΛΙΚΗ ΖΗΜΙΑ.

A UTILIZAÇÃO DE ECRÃS PLANOS QUE EXCEDAM A CAPACIDADE DE PESO MÁXIMA DESTA PRODUTO PODERÁ RESULTAR NA AVARIA DO PRODUTO E CAUSAR POSSÍVEIS DANOS CORPORAIS E/OU MATERIAIS.

BRUG MED FLADSKÆRME, HVIS VÆGT OVERSKRIDER DETTE PRODUKT MAKSIMALE KAPACITET, KAN RESULTERE I PRODUKTETS DRIFTSSVIGT OG MULIGVIS SKADE OG ELLER EJENDOMSSKADE.

TÄMÄN TUOTTEEN SUURIMMAN PAINORAJAN YLITTÄMINEN TAULUTELEVISIOIDEN KANSSA KÄYTETTÄESSÄ, SAATTA JOHTAA TUOTTEEN VIOITTUMISEEN JA AIHEUTTAA MAHDOLLISESTI LOUKKAANTUMISEN JA/TAI OMAISUUSVAHINGON.

ANVÄNDNING MED PLATTSKÄRMAR SOM ÖVERSKRIDER VIKTKAPACITETEN FÖR DENNA PRODUKT KAN LEDA TILL ATT PRODUKTEN GÅR SÖNDER, MÖJLIG PERSONSKADA ELLER SKADA PÅ EGENDOM.

UTILIZAREA CU ECRANE PLATE CARE DEPĂȘESC CAPACITATEA MAXIMĂ DE GREUTATE A ACESTUI PRODUS POATE CAUZA DEFECTAREA PRODUSULUI ȘI POSIBILE RĂNIRI ȘI SAU PAGUBE MATERIALE.

ИСПОЛЗВАНЕ С ПЛОСКИ ПАНЕЛИ, НАДВИШАВАЩИ МАКСИМАЛНАТА ТОВАРОНОСИМОСТ НА ТОЗИ ПРОДУКТ, МОЖЕ ДА ДОВЕДЕ ДО ПОВРЕДА НА ПРОДУКТА С ЕВЕНТУАЛНО НАРАНЯВАНЕ И/ИЛИ МАТЕРИАЛНИ ЩЕТИ.

TOOTE KASUTAMINE LAMEEKRAANIDEGA, MILLE MAKSIMAALNE MASS ÜLETAB SELLE TOOTE KANDEVÕIMET, VÕIB PÕHJUSTADA TOOTE KATKINEKU, MILLE TAGAJÄRJESK VÕIB OLLA VIGASTUS JAVÕI VARA KAHJUSTUMINE.

IZMANTOŠANA AR PLAKANIEM PANEĻIEM, KAS PĀRSNIEDZ MAKSIMĀLO ŠĪ IZSTRĀDĀJUMA NESTSPĒJU, VAR IZRAISĪT IZSTRĀDĀJUMA BOJĀJUMUS, KAS VAR IZRAISĪT IESPĒJAMAS TRAUMAS UN VAI ĪPAŠUMA BOJĀJUMUS.

JEI NAUDOJAMA SU PLOKŠČIAISIAIS VAIZDUOKLIAIS, KURIŲ SVORIS VIRŠIJA MAKSIMALŲ ŠIO GAMINIO ATLAIKOMĄ SVORĮ, GAMINYS GALI SUGESTI. DĖL TO GALI BŪTI SUŽALOTI ŽMONĖS ARBA PADARYTA ŽALA TURTUI.

UPORABA TEGA IZDELKA ZA PLOSKE ZASLONE, KI PRESEGAJO NAJVEČJO DOVOLJENO TEŽO TEGA IZDELKA, LAHKO POVZROČI LOMLJENJE IZDELKA IN POSLEDIČNE TELESNE POŠKODBE ALI POŠKODBE LASTNINE.

POUŽITIE S PLOCHÝMI PANEĽMI PREKRAČUJÚCIMI MAXIMÁLNŤU HMOTNOSTNŤU KAPACITU TOHTO VÝROBKU MÔŽE MAŤ ZA NÁSLEDOK ZLYHANIE VÝROBKU S NÁSLEDKOM PRÍPADNÝCH ÚRAZOV A/ ALEBO POŠKODENIU MAJETKU.

ИСПОЛЬЗОВАНИЕ ТЕЛЕВИЗИОННЫХ ПАНЕЛЕЙ, ВЕС КОТОРЫХ ПРЕВЫШАЕТ МАКСИМАЛЬНО ДОПУСТИМЫЙ ВЕС НАГРУЗКИ ЭТОГО ИЗДЕЛИЯ, МОЖЕТ СТАТЬ ПРИЧИНОЙ ПОЛОМКИ ИЗДЕЛИЯ И ПОЛЕЧЬ ВОЗМОЖНЫЕ ТРАВМЫ И МАТЕРИАЛЬНЫЙ УЩЕРБ.

BU ÜRÜNÜN MAKSİMUM AĞIRLIK KAPASİTESİNİ AŞAN FLAT PANEL TELEVİZYONLARLA KULLANIM, ÜRÜNÜN BOZULMASINA YOL AÇARAK KİŞİSEL YARALANMA VE/VEYA MAL ZARARINA NEDEN OLABİLİR.

BRUK AV FLATSKJERMER SOM OVERSTIGER DEN MAKSIMALE VEKTKAPASITETEN FOR DETTE PRODUKTET KAN RESULTERE I AT PRODUKTET KOLLAPSER OG FØRER TIL PERSONLIG SKADE OG/ELLER MATERIELL SKADE.

使用超过本产品最大重量能力的平板电视可能导致产品故障，造成人身伤害或财产损坏。

耐荷重を超えるフラットパネルに本製品を使用すると、製品が破損し、けがをしたり、壁などが破損する場合があります。

TOOLS NEEDED - NOT INCLUDED

Tools Needed

Herramientas necesarias
 Outils requis
 Benötigte Werkzeuge
 Benodigde gereedschappen
 Strumenti necessari
 Potrzebne narzędzia
 Potřebné nástroje
 Szükséges eszközök
 Απαιτούμενα εργαλεία
 Ferramentas necessárias
 Nødvendigt værktøj
 Tarvittavat työkalut
 Verktyg som krävs
 Instrumente necesare
 Необходимы уреди
 Vajalikud tööriistad
 Nepieciešamie rīki
 Reikalingi įrankiai
 Potrebno orodje
 Potřebné náradie
 Необходимые инструменты
 Gerekli Aletler
 Nødvendige verktøy
 قېز آلدا، تاودالا
 需要的工具
 必要なツール

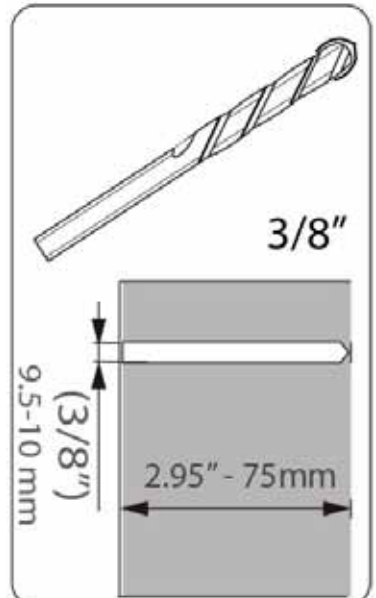
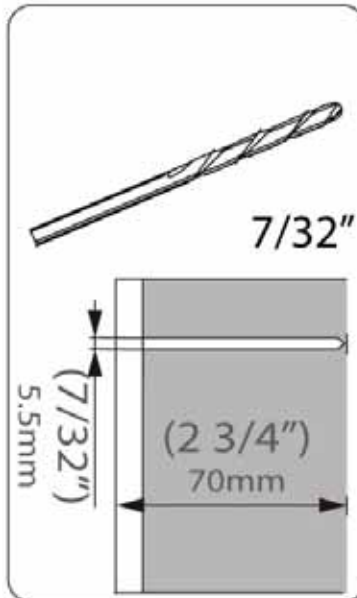
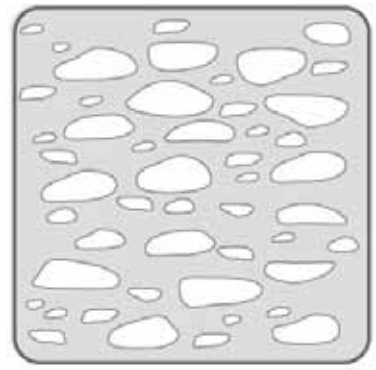
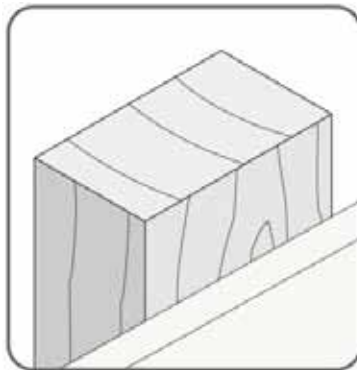
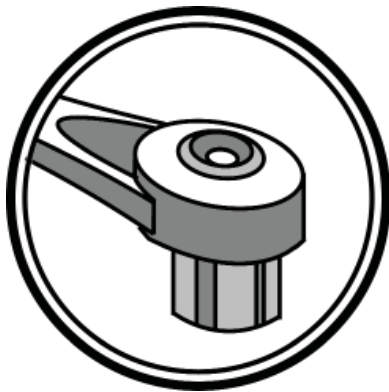

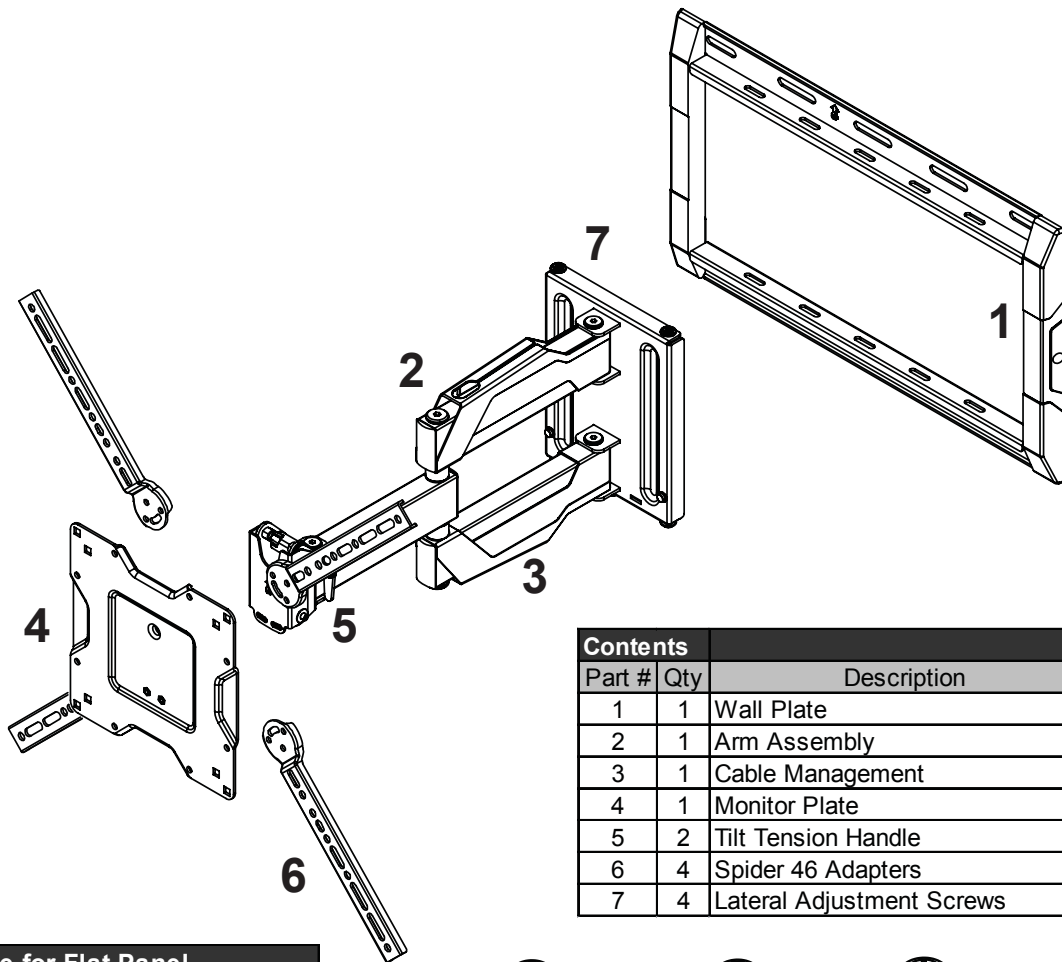

Contents		
Part #	Qty	Description
1	1	Wall Plate
2	1	Arm Assembly
3	1	Cable Management
4	1	Monitor Plate
5	2	Tilt Tension Handle
6	4	Spider 46 Adapters
7	4	Lateral Adjustment Screws

Screws / Hardware for Flat Panel

Part #	Qty	Description
M-A	4	Philips screws M4 x 15mm
M-B	4	Philips screws M4 x 30mm
M-C	4	Philips screws M5 x 15mm
M-D	4	Philips screws M5 x 30mm
M-E	4	Philips screws M6 x 15mm
M-F	4	Philips screws M6 x 30mm
M-G	4	Philips screws M8 x 15mm
M-H	4	Philips screws M8 x 30mm
M-I	4	Round Spacers: M6-M8 x 5mm
M-J	4	Round Spacers: M6-M8 x 10mm
M-K	4	Round Washers: M4-M5
M-L	4	Round Washers: M6-M8

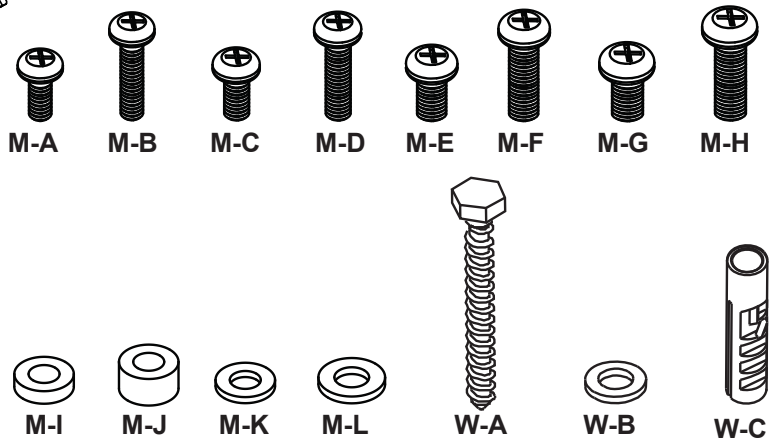

Wall Kit

Part #	Qty	Description
W-A	4	Lag Bolts (8mm x 65mm)
W-B	4	Steel Washer
W-C	4	Wall Anchor (10mm OD x 8mm ID)

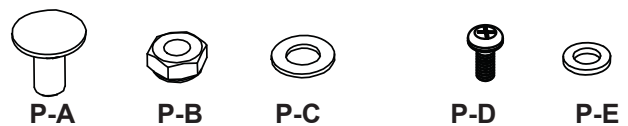

Specialty Hardware

Part #	Qty	Description
P-A	8	Carriage Bolt
P-B	8	Nylock Nut
P-C	8	Washer
P-D	2	Phillips Screw M4x8mm
P-E	2	M4 Washer
P-F	1	Allen Wrench
P-G	1	Closed Wrench

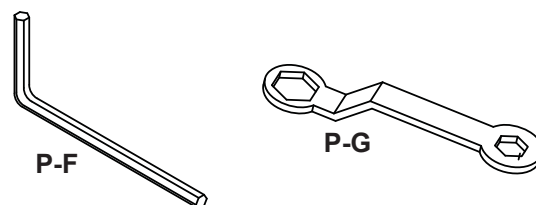

A

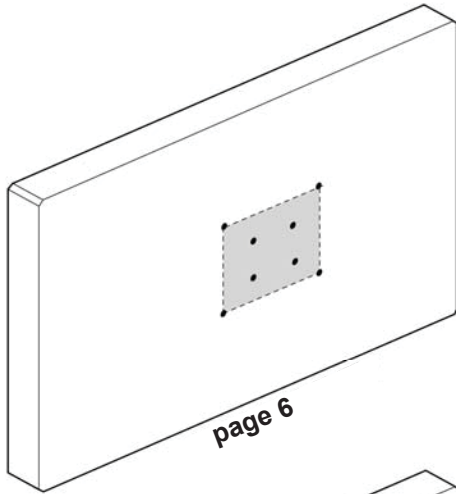

B

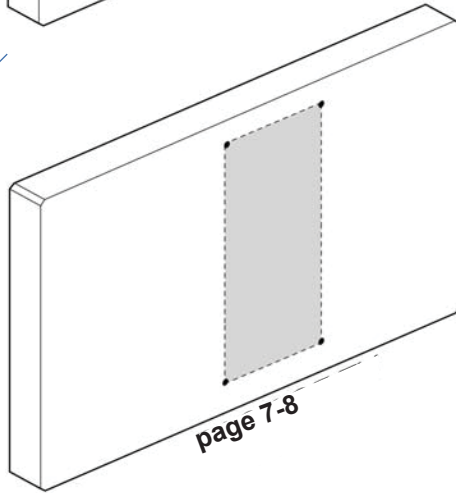

C

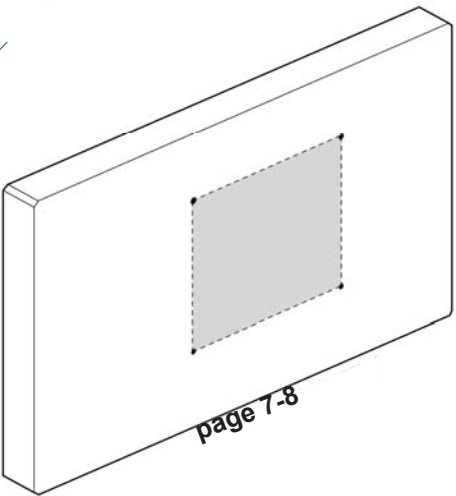

D

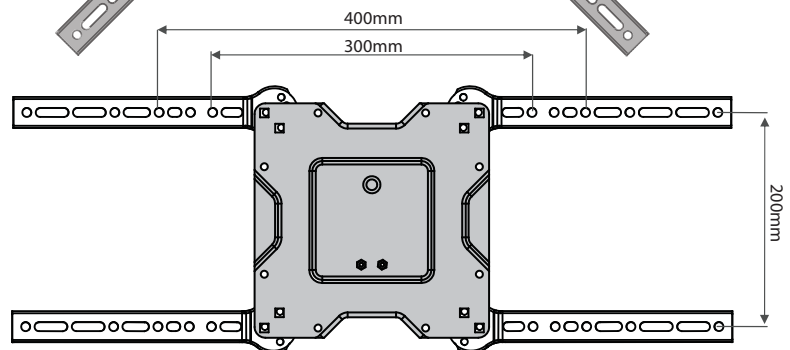
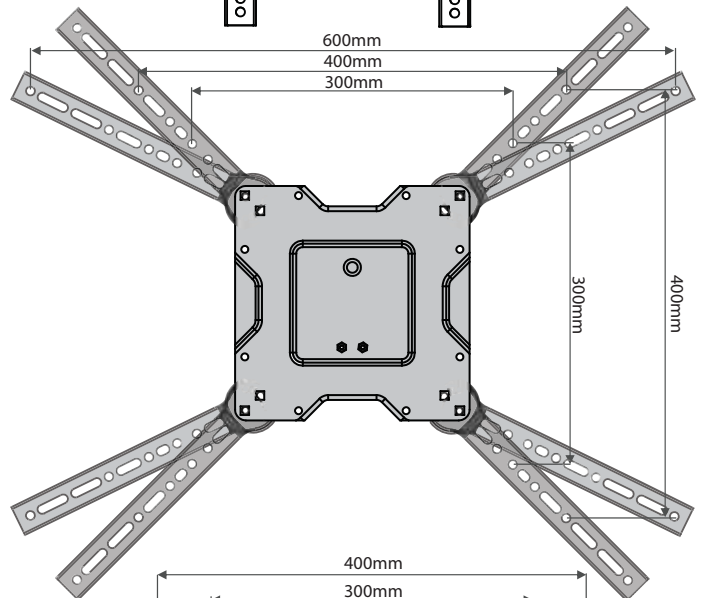
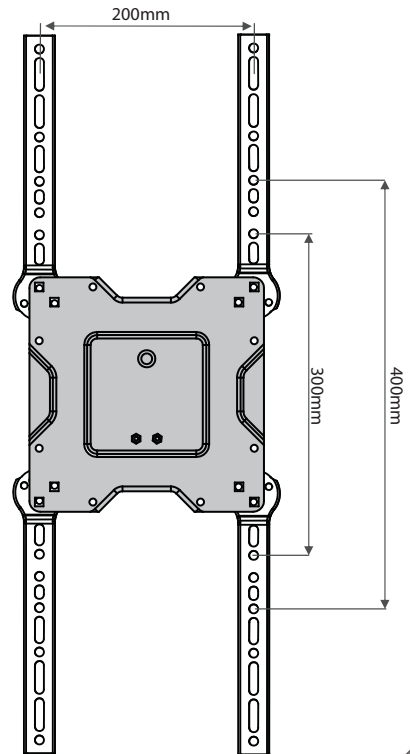
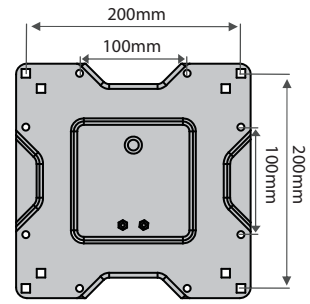
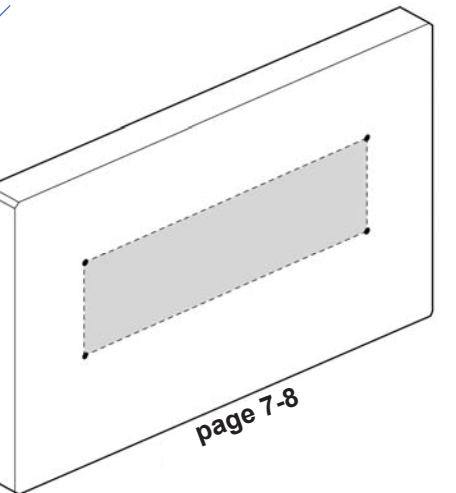

STEP 1 A: ≤ 200mm X 200mm

Attach monitor using monitor hardware, M-A, M-B, etc...

Coloque la pantalla utilizando los materiales de instalación de la pantalla, M-A, M-B, etc...
 Installer le moniteur avec les fixations de moniteur, M-A, M-B, etc...
 Bringen Sie den Bildschirm mit den Bildschirm-Befestigungsteilen M-A, M-B usw. an.
 Bevestig monitor via monitor hardware, M-A, M-B, enz...
 Fissare il monitor utilizzando i componenti di montaggio, M-A, M-B, ecc...
 Zamontuj monitor, używając narzędzi dołączonych do monitora, M-A, M-B, itp...
 Pripěvněte monitor pomocí k tomu určených dílů, M-A, M-B, apod.
 Szerelje fel a monitort az M-A, M-B stb. monitorszerelvényel...
 Τοποθετήστε την οθόνη με το υλικό οθόνης, M-A, M-B, κ.λπ...
 Prender o monitor utilizando o equipamento do monitor, M-A, M-B, etc...
 Pásæt skærm ved hjælp af skærm-hardware, M-A, M-B osv...
 Kiinnitä näyttö käyttämällä näytön osia, M-A, M-B jne.
 Fäst bildskärm genom att använda bildskärmshårdvara, M-A, M-B, etc...
 Ataşați monitorul utilizând structura hardware pentru monitor, M-A, M-B etc...
 Прикачете монитора, като използвате хардуер за монитор, M-A, M-B и др...
 Kinnitage ekraan ekraani paigaldusosade abil, M-A, M-B jne...
 Piestipriniet monitoru, izmantojot monitora detaļas, M-A, M-B utt.
 Pritvirtinti monitorių naudojant monitoriaus aparatūrą, M-A, M-B ir t.t.
 Pritrdite monitor s pomočjo kovinskih delov za monitor, M-A, M-B itd...
 Pripěvnite obrazovku pomocou na to určených dielov, M-A, M-B atd.
 Прикрепите монитор с помощью крепежа для монитора, M-A, M-B, и т. д.
 Monitor donanımı, M-A, M-B vb. kullanarak monitörü takın...
 Fest skjermen med skjermdelelene M-A, M-B etc...
 خال، م-ا، م-ب تامازل تاسم م ادخ تساب باق رمل طبرا
 使用显示器硬件 M-A、M-B 等联接显示器
 モニタハードウェア、M-A、M-Bなどを使って、モニタを取り付けます。

A

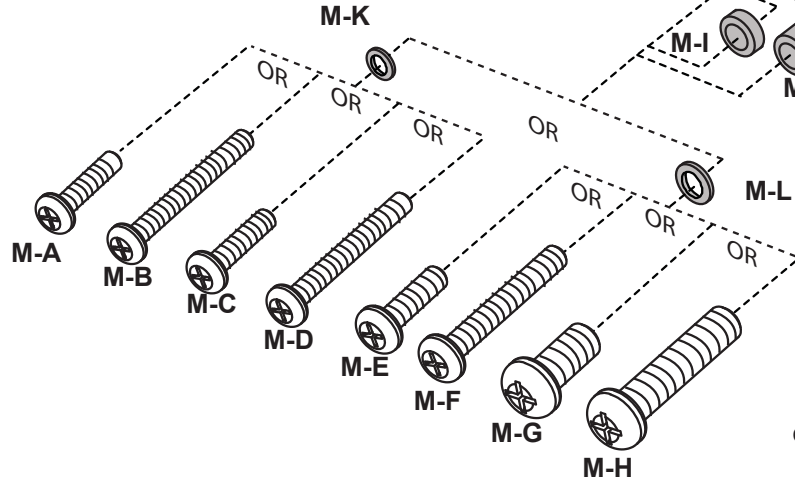
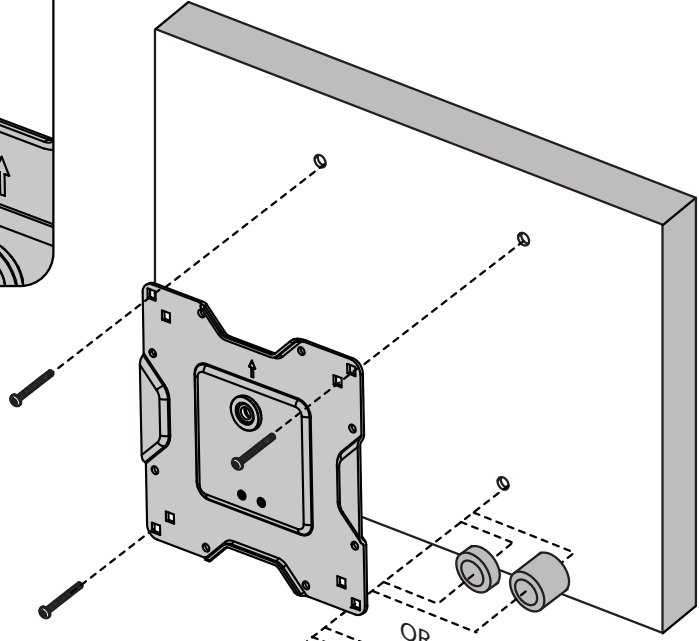
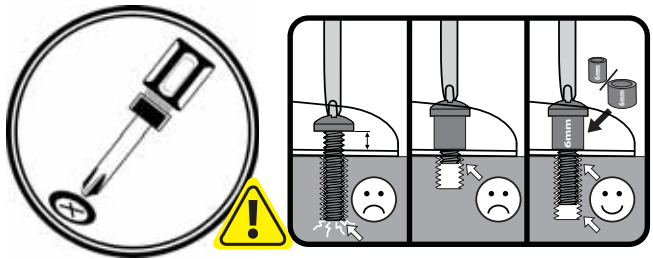
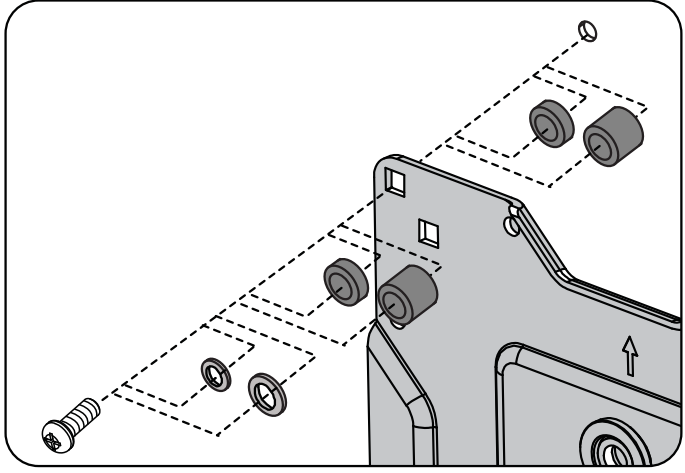
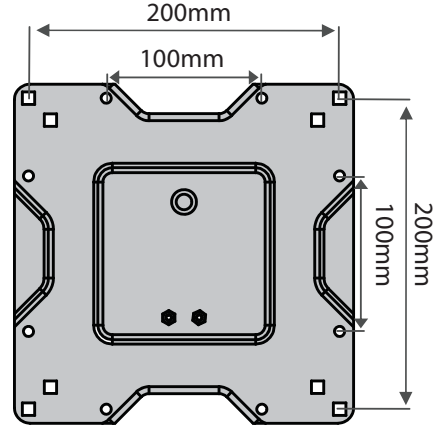

continue installation on page 9

STEP 1 B/C/D: > 200mm X 200mm - INSTALL ADAPTERS

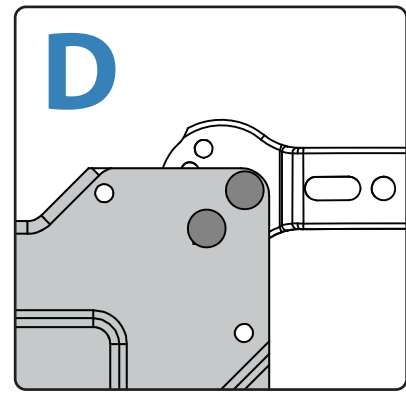
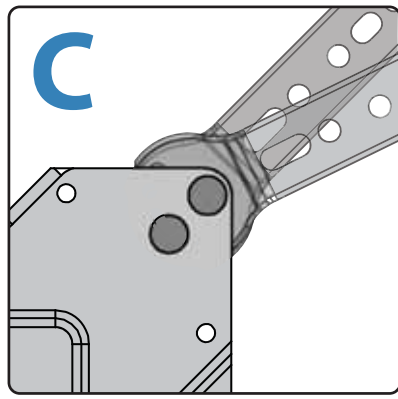
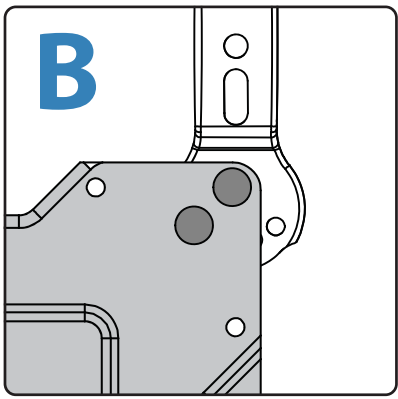
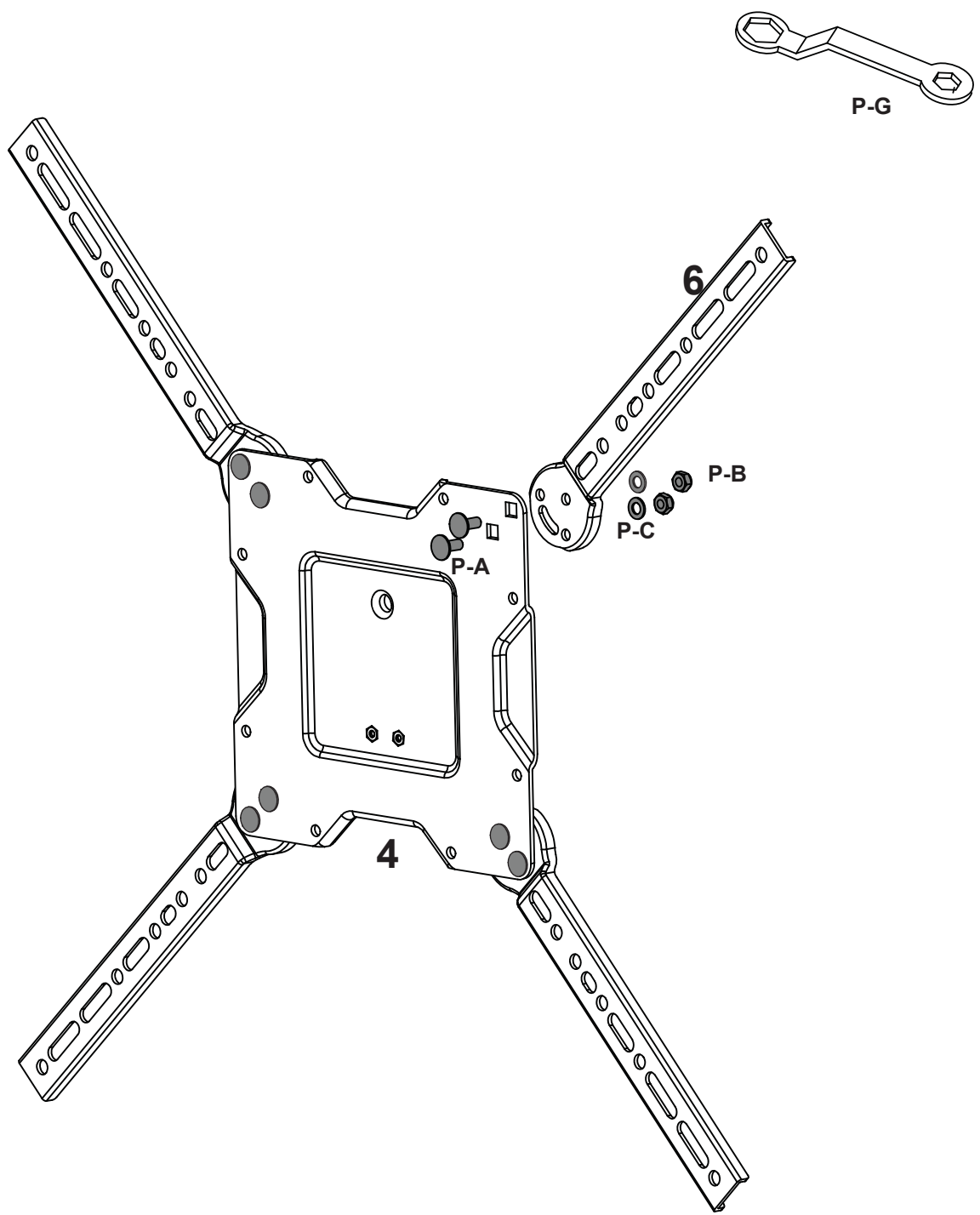

STEP 1 B/C/D: > 200mm X 200mm

Attach monitor using monitor hardware, M-A, M-B, etc...

Coloque la pantalla utilizando los materiales de instalación de la pantalla, M-A, M-B, etc...

Installer le moniteur avec les fixations de moniteur, M-A, M-B, etc...

Bringen Sie den Bildschirm mit den Bildschirm-Befestigungsteilen M-A, M-B usw. an.

Bevestig monitor via monitor hardware, M-A, M-B, enz...

Fissare il monitor utilizzando i componenti di montaggio, M-A, M-B, ecc...

Zamontuj monitor, używając narzędzi dołączonych do monitora, M-A, M-B, itp...

Připevněte monitor pomocí k tomu určených dílů, M-A, M-B, apod.

Szerelje fel a monitort az M-A, M-B stb. monitorszerelvényekkel...

Τοποθετήστε την οθόνη με το υλικό οθόνης, M-A, M-B, κ.λπ...

Prender o monitor utilizando o equipamento do monitor, M-A, M-B, etc....

Pásæt skærm ved hjælp af skærm-hardware, M-A, M-B osv...

Kiinnitä näyttö käyttämällä näyttön osia, M-A, M-B jne.

Fäst bildskärm genom att använda bildskärmshårdvara, M-A, M-B, etc...

Ataşați monitorul utilizând structura hardware pentru monitor, M-A, M-B etc...

Прикачете монитора, като използвате хардуер за монитор, M-A, M-B и др....

Kinnitage ekraan ekraani paigaldusosade abil, M-A, M-B jne...

Piestipriniet monitoru, izmantojot monitora detaļas, M-A, M-B utt.

Pritvirtinti monitorių naudojant monitoriaus aparatūrą, M-A, M-B ir t.t.

Pritrdite monitor s pomočjo kovinskih delov za monitor, M-A, M-B itd....

Pripevnite obrazovku pomocou na to určených dielov, M-A, M-B atd.

Прикрепите монитор с помощью крепежа для монитора, M-A, M-B, и т. д.

Monitör donanımı, M-A, M-B vb. kullanarak monitörü takın...

Fest skjermen med skjermdelelene M-A, M-B etc...

بإقراءملا تامزلتسم مادختساب بإقراءملا طبرا، M-A، M-B، إلخ.

使用显示器硬件 M-A、M-B 等联接显示器

モニタハードウェア、M-A、M-Bなどを使って、モニタを取り付けます。

B

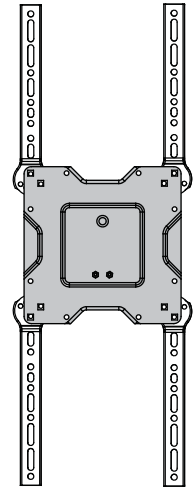

C

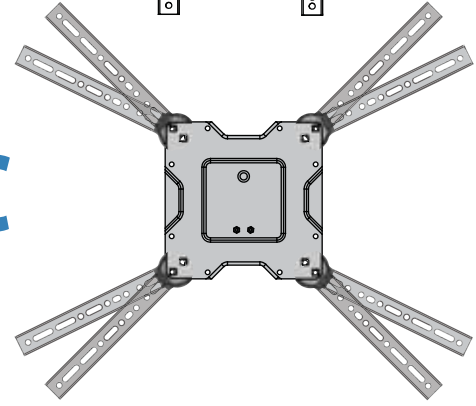

D

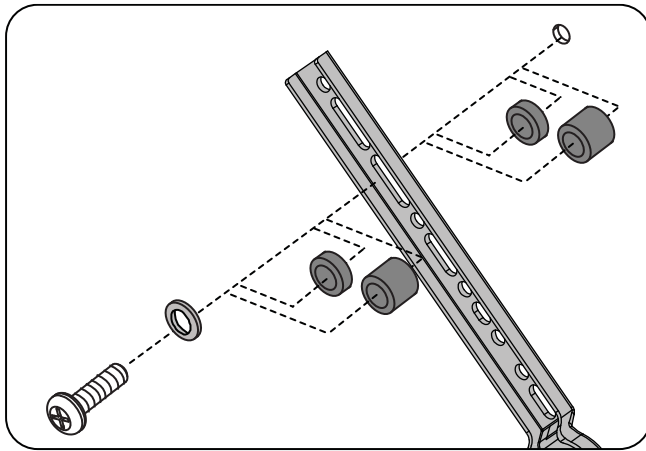
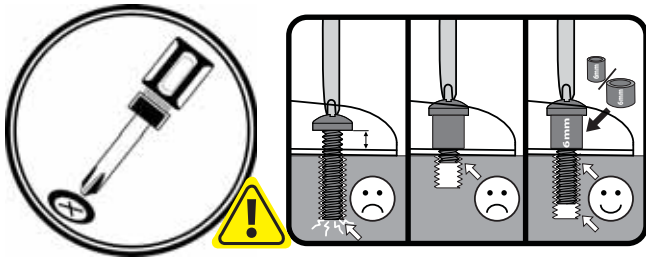
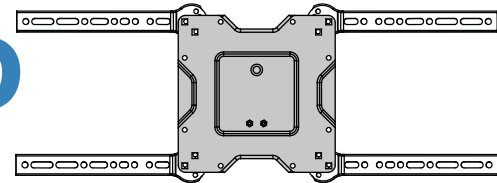

Note: M4 screws (Part M-A, M-B) should not be used for hole patterns greater than 200mm x 200mm.

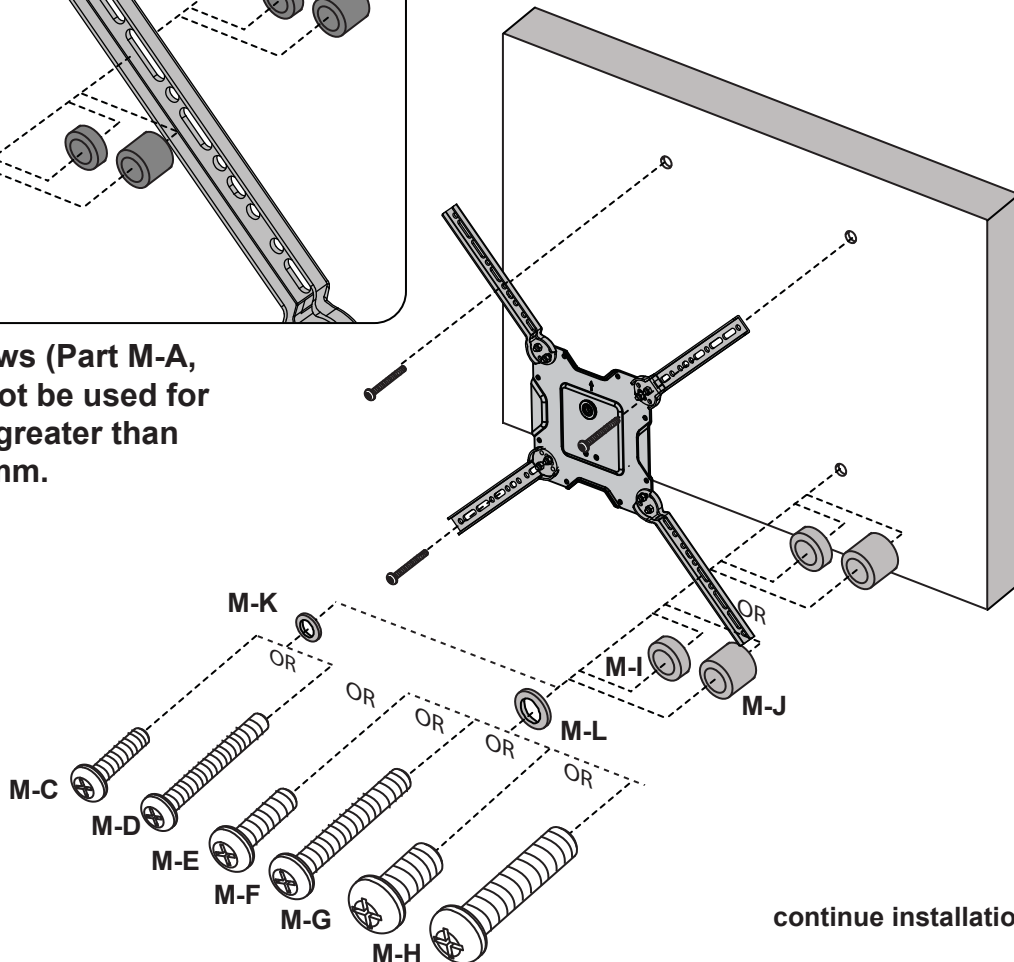

continue installation on page 9

STEP 2 - WOOD STUD INSTALLATION

Remove

Retire
Retirez
Entfernen Sie
Verwijder
Rimuovere
Zdejmij
Odstraňte
Távolítsa el
Αφαιρέστε
Desmontar
Fjern
Poista
Ta bort
Scoateți
Отстрани
Eemaldage
Noņemt
Pašalinti
Odstranite
Odstráňte
Удалите
Kaldır
Fjern
拆除
取り外し
لڙا

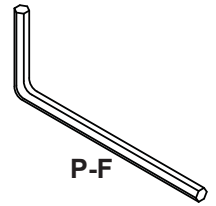

Set aside until later step

Guarde aparte para un paso posterior
Mettre de côté pour une étape ultérieure
Bis zu einem späteren Schritt zur Seite legen
Leg opzij voor later
Conservare queste parti per un passaggio successivo
Odłożyć do późniejszego etapu
Uložit stranout pro další krok
Tegyé félre, egy későbbi lépésben lesz rá szüksége
Φυλάξτε για μετέπειτα βήμα
Colocar de lado até um passo posterior
Sæt til side indtil et senere punkt
Aseta sivuun myöhempää vaihetta varten
Lägg åt sidan till senare steg
Păstrați pentru o etapă ulterioară
Остави настрана за по-късна стъпка
Range kõrvale hilisemas sammus kasutamiseks.
Atlieciet uz vēlāku posmu
Atidēkrite iki kito etapo
Postavite na stran do koraka v nadaljevanju
Nastavte stranou, až do neskoršieho kroku
Отложите в сторону до следующего этапа.
Sonrakı adımı kadar kenara koyun
Legg til side til senere
تق ح ال قوطخ ب م ا ق ل ا ن ح ل ا ب ن ا ج ع ض و ي
放置到一侧，直至进行后续步骤
後の手順のために、取っておきます。

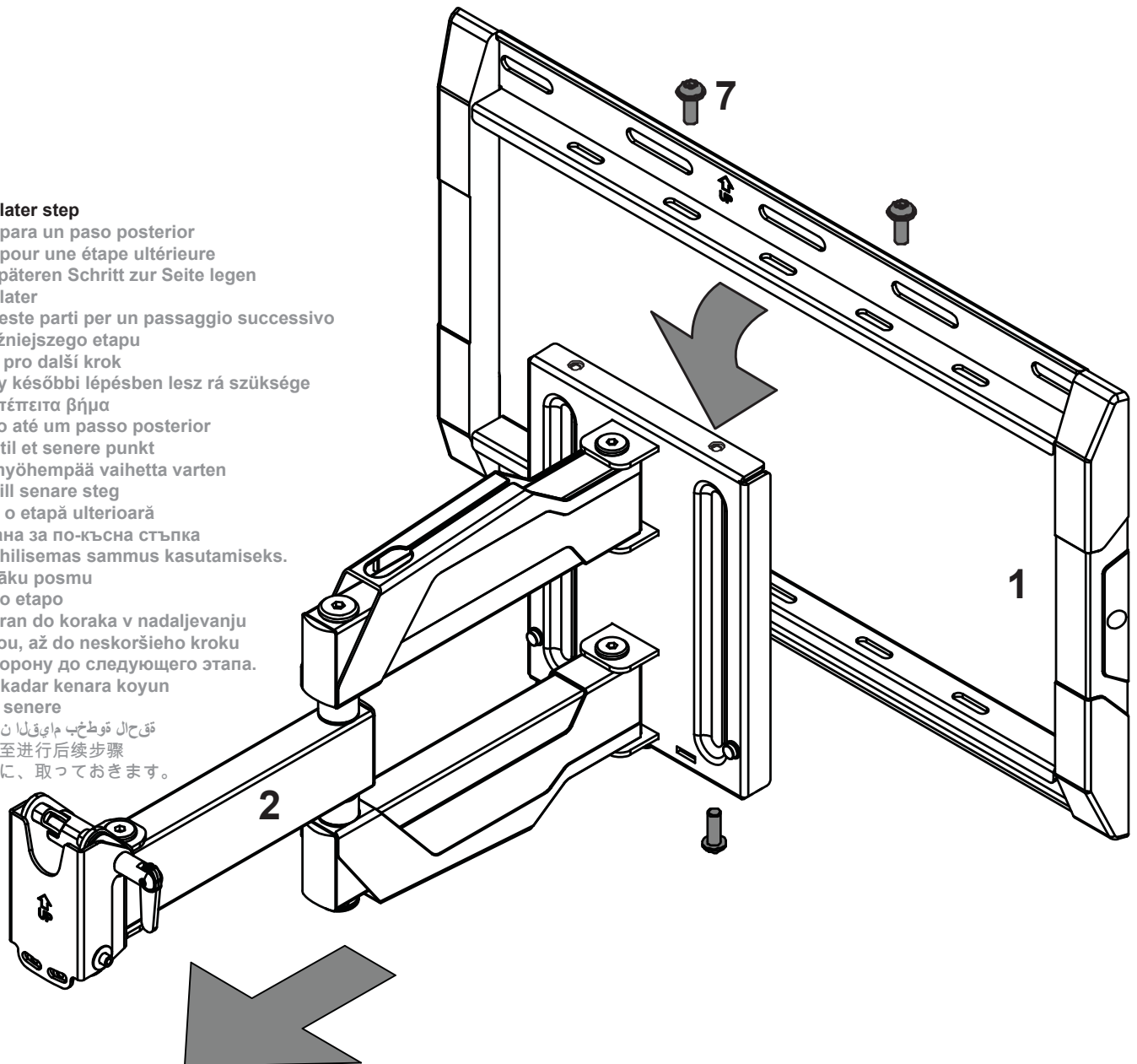

STEP 3 - WOOD STUD INSTALLATION

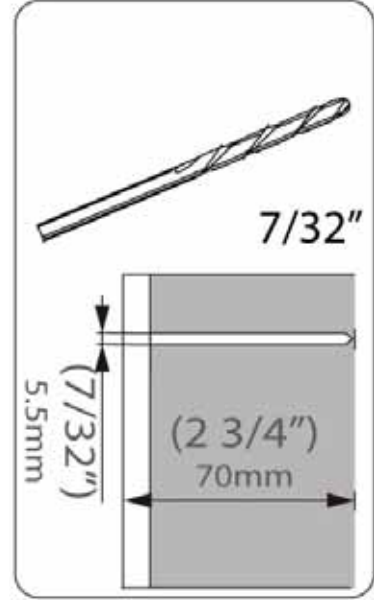
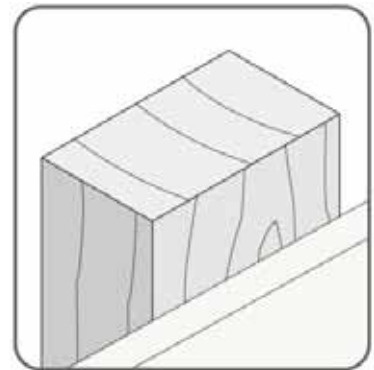
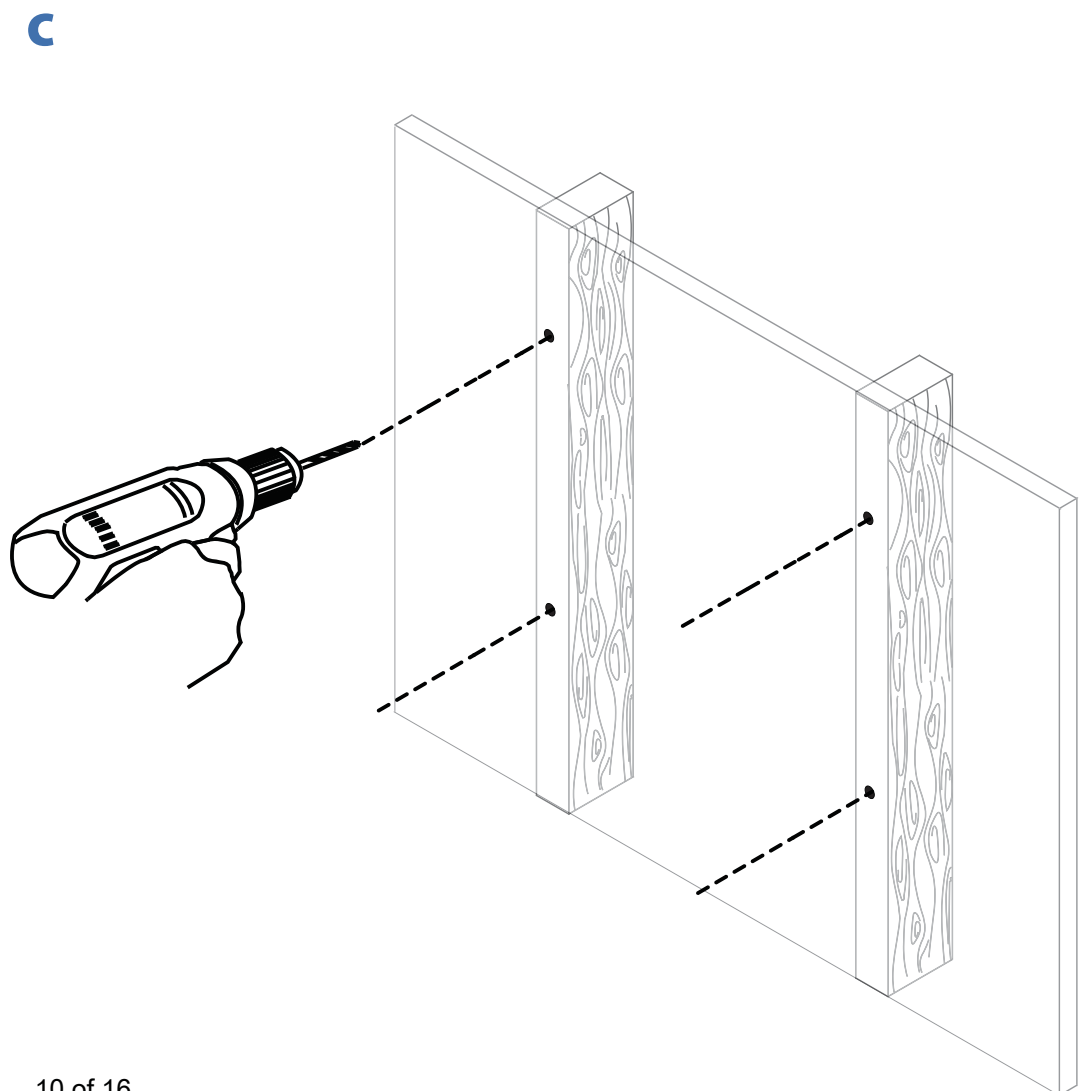
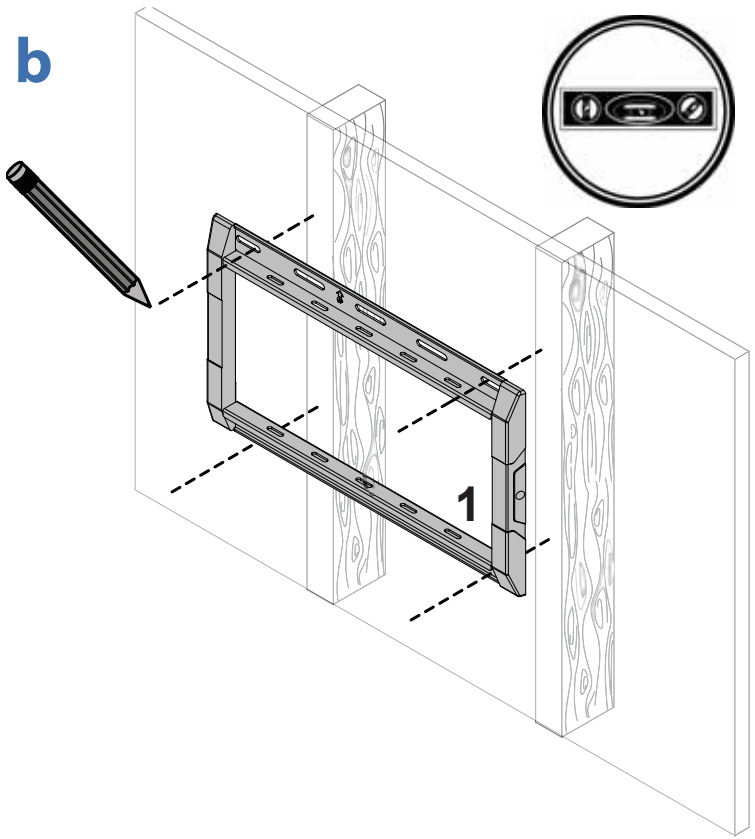
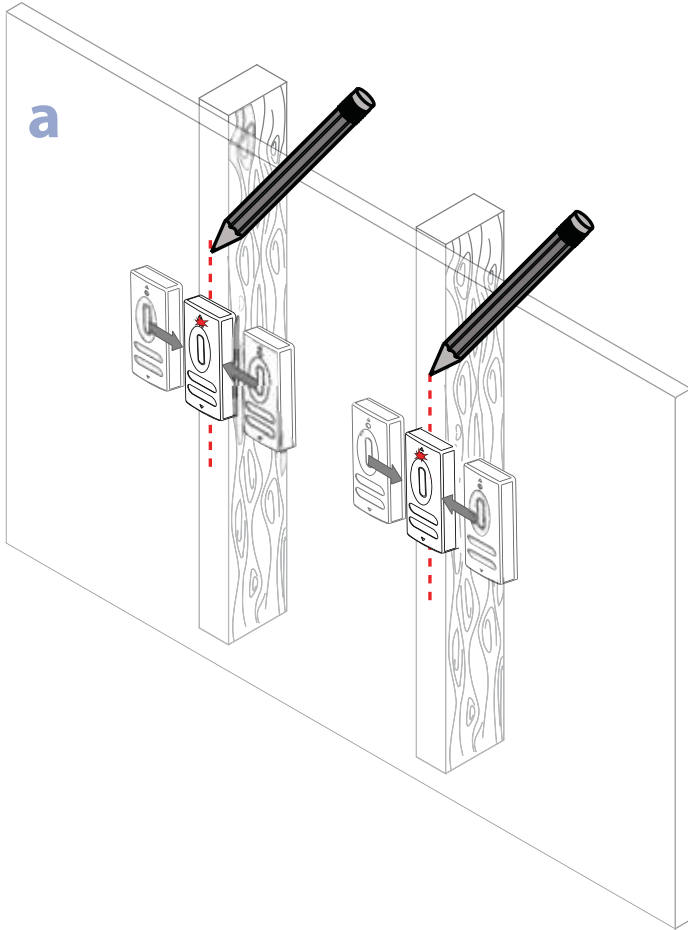

STEP 3 - SOLID WALL INSTALLATION

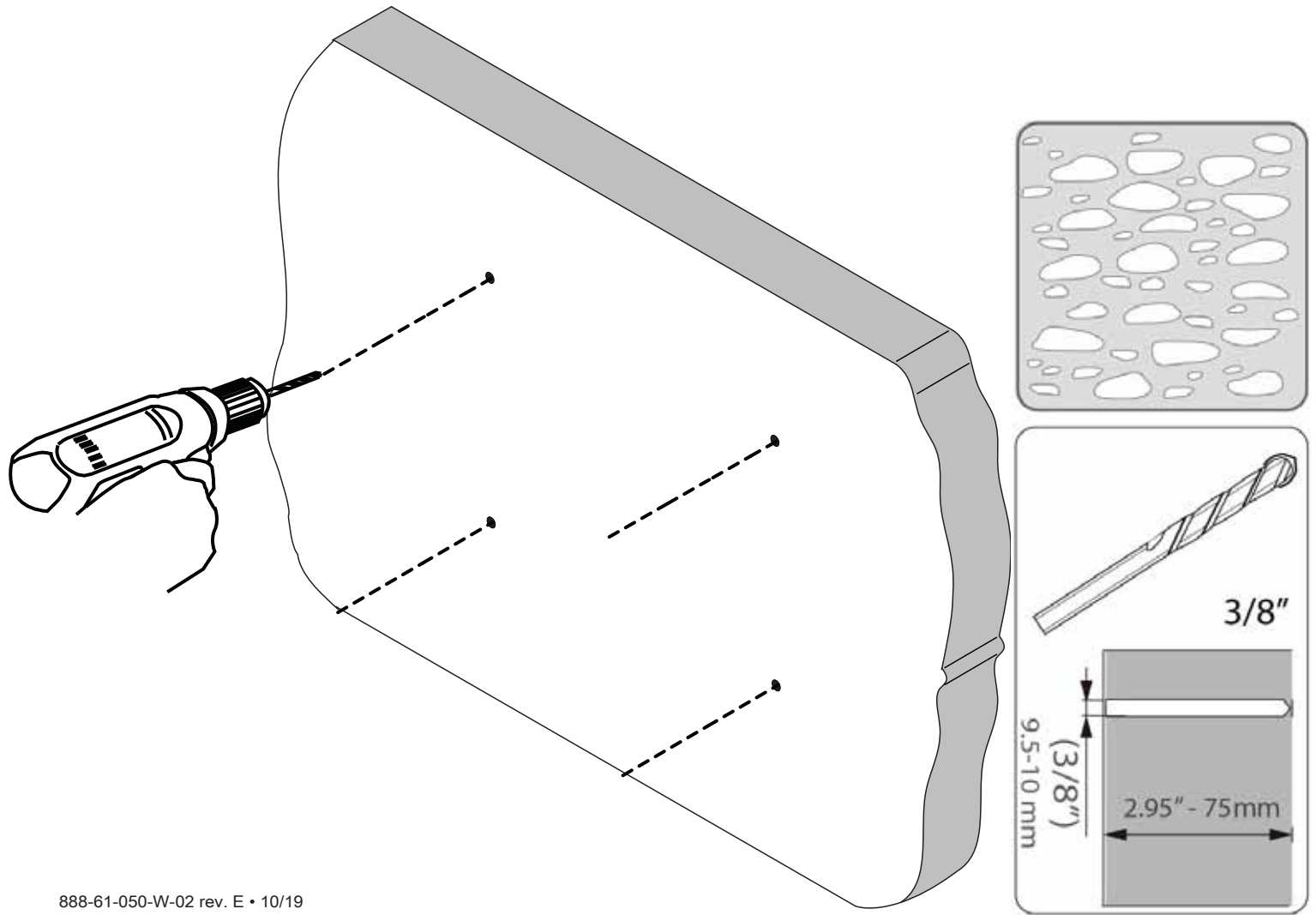
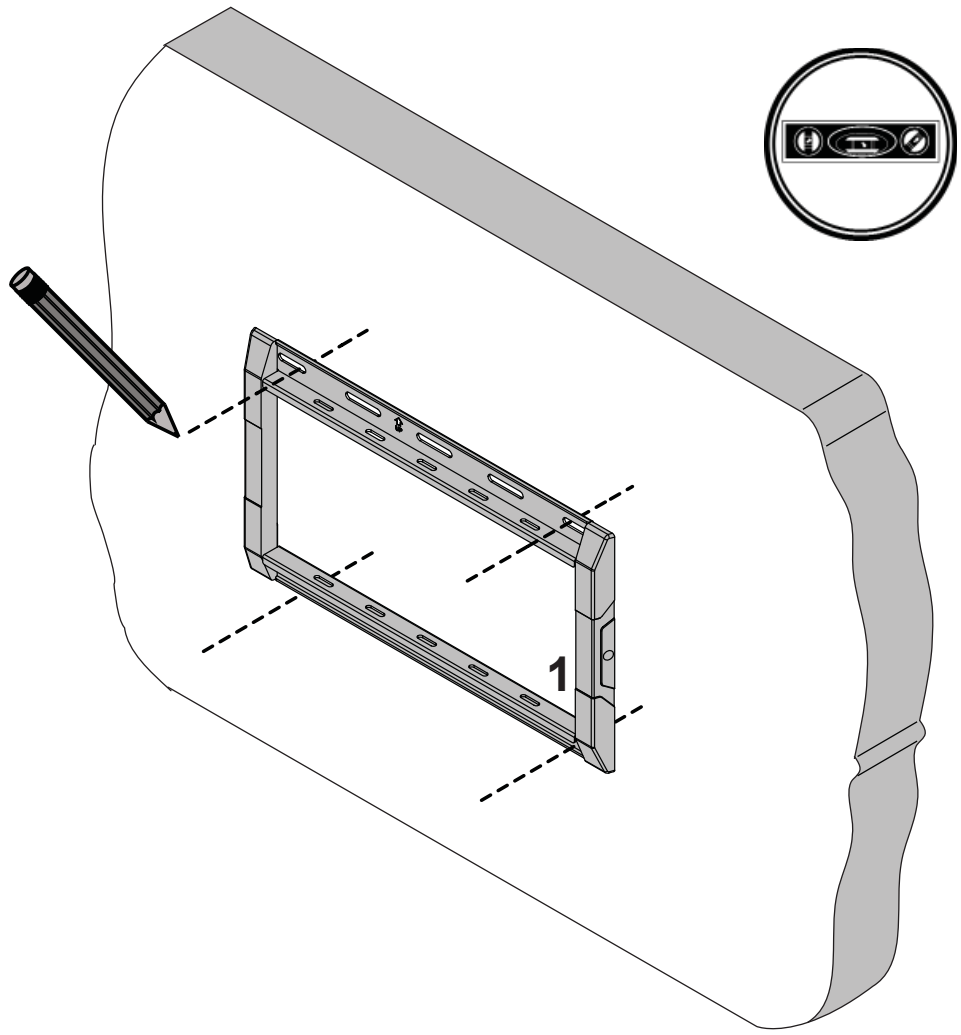

STEP 4 - WOOD STUD INSTALLATION

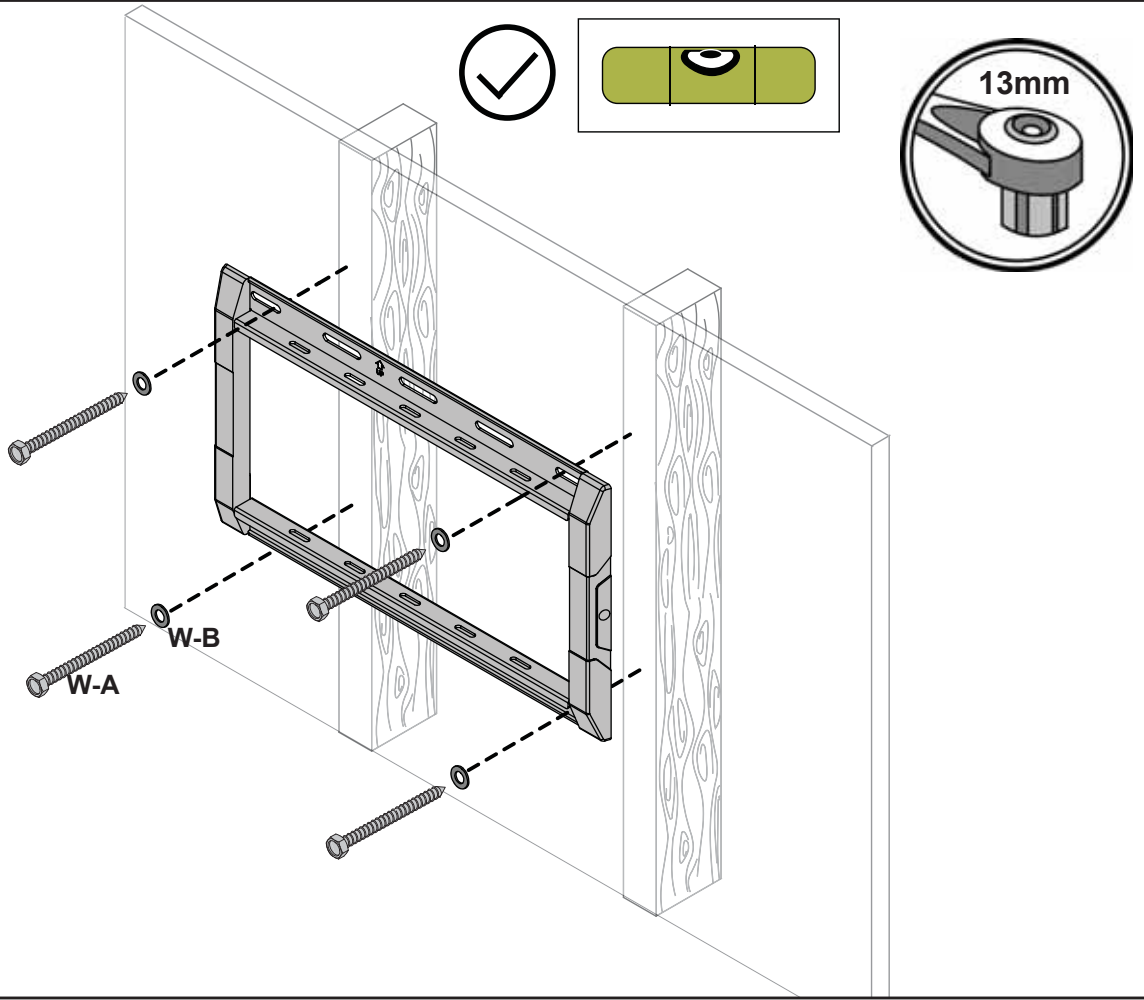

STEP 4 - SOLID WALL INSTALLATION

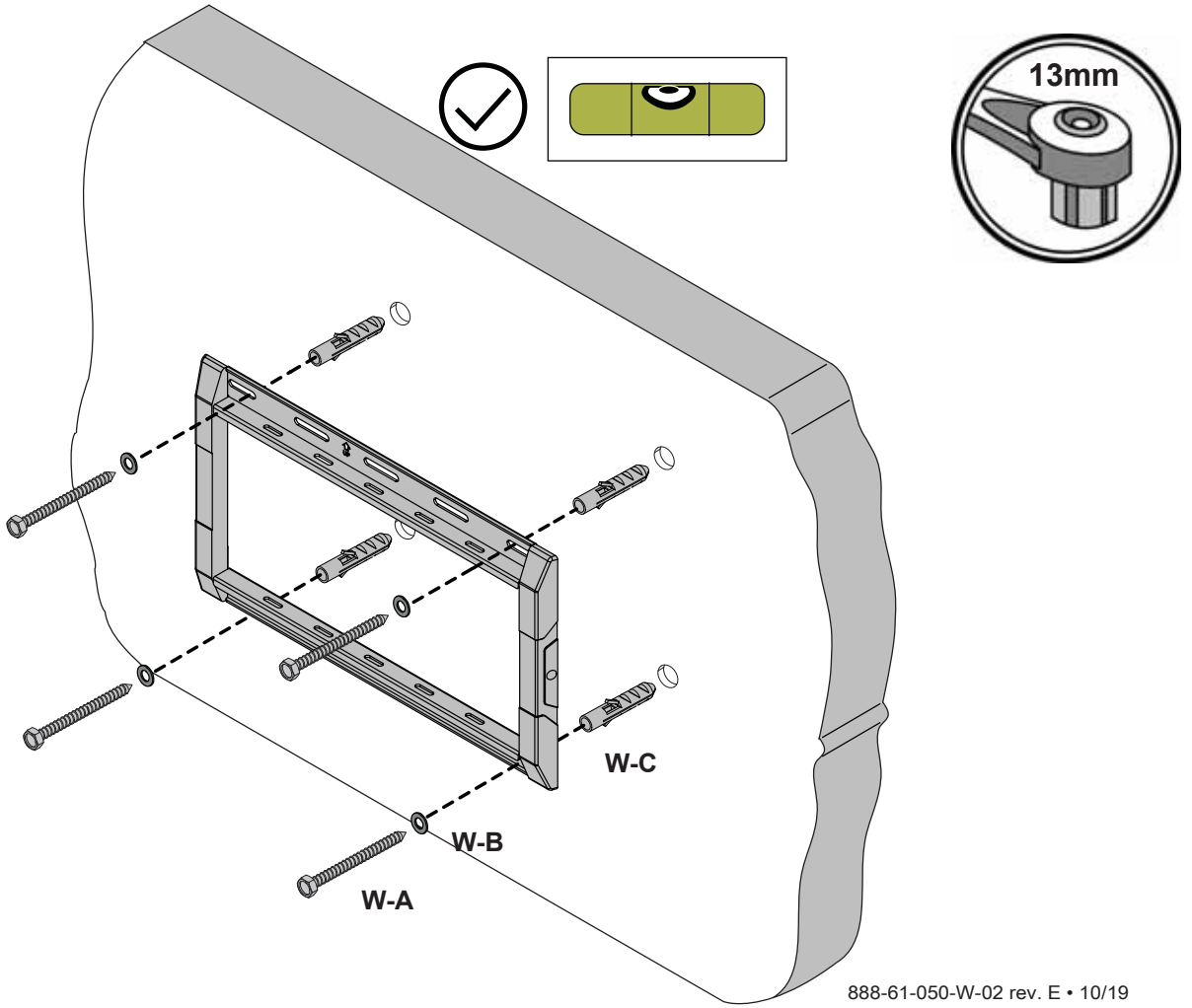

STEP 5

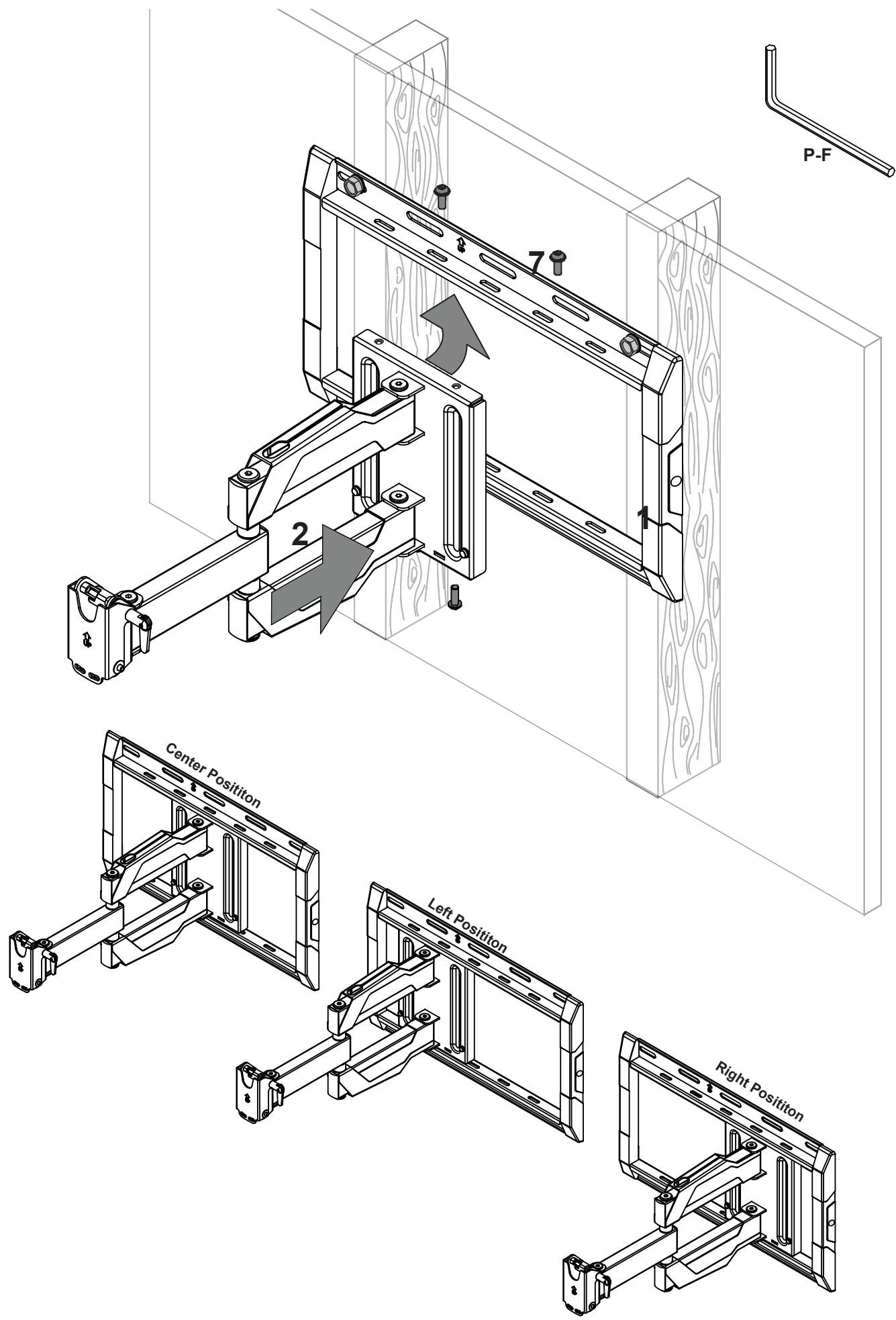

NOTE: For safe and proper installation be sure to install the 4 locking screws as shown.

STEP 6 - HANG TV

Hang with monitor attached

Cuelgue con el monitor adherido.
 Accrochez avec le moniteur installé.
 Mit dem befestigten Monitor aufhängen.
 Hang op terwijl de monitor is bevestigd.
 Appendere con lo schermo attaccato.
 Powieś z przymocowanym monitorem.
 Zaveste s připevněným monitorem.
 Fűgessze fel a monitorral együtt.
 Кремі́сте ме́ την οθόνη προσαρτημένη
 Suporte com monitor preso
 Hæng op med skærm påsat
 Ripusta näyttö kiinnitetynä
 Häng med bildskärm fastsatt
 Agățați cu monitorul atașat
 Закачи с монитора прикрепен
 Riputage koos kinnitatud ekraaniga
 Piekārt ar pievienoto monitoru
 Pakabinti su pritvirtintu monitoriumi
 Obesite s pritrjenim monitorjem
 Zaveste s pripevnenou obrazovkou.
 Навесіть с установленим монітором.
 Takılı monitörle asın
 Heng med skjermen festet
 اطوپرم باقارملاو قیلعتلاب مق
 在显示器已联接的条件下悬挂
 モニタを取り付けた状態で掛けます。

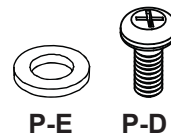
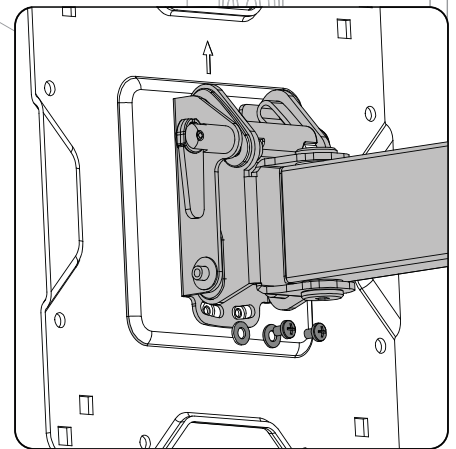
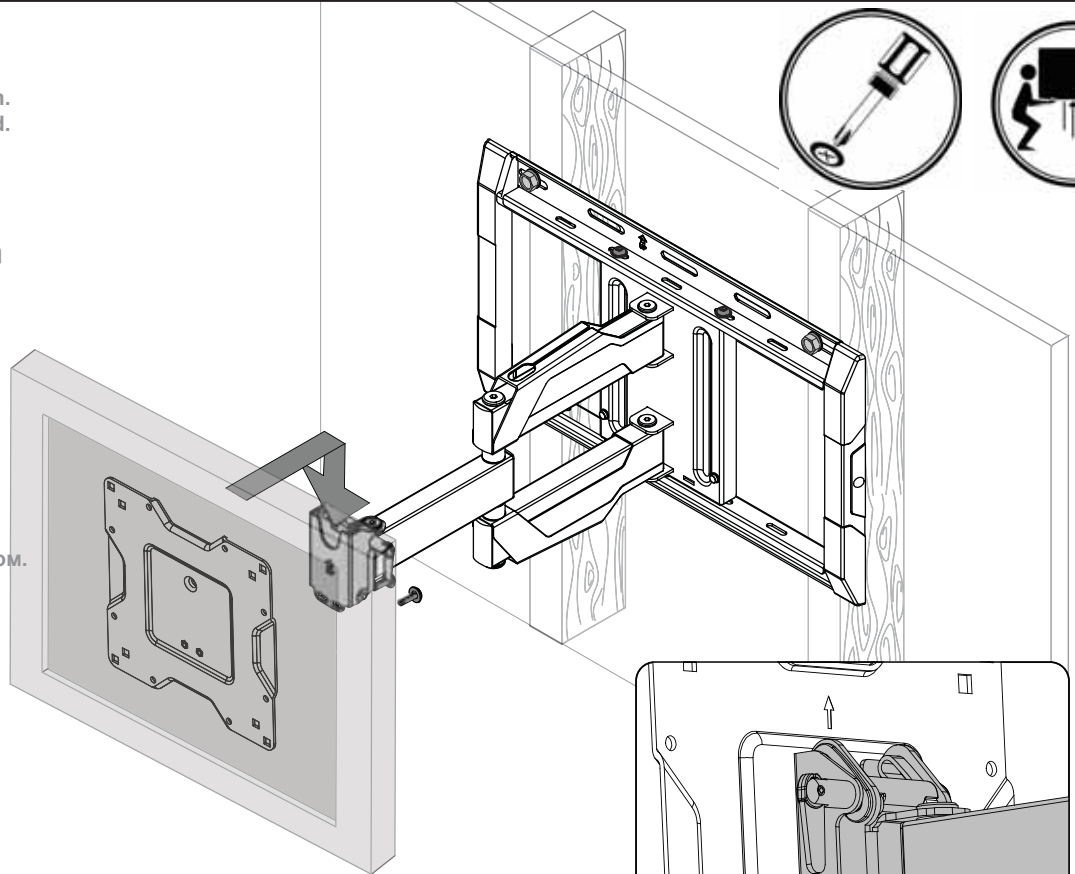

NOTE: For safe and proper installation be sure to install the locking /leveling screws as shown.

STEP 7 - LEVEL TV

Level
 Nivel
 Niveau
 Wasserwaage
 Waterpas
 Livellare
 Poziomnica
 Vodováha
 Szintező
 Αλφάδι
 Nivel
 Vaterpas
 Vesivaaka
 Pass
 Nivelă
 Ниво
 Lood
 Līmenis
 Lygis
 Vodna tehnica
 Vodováha
 Уровень
 Aynı Seviyeye Getir
 Vater
 نازي م
 水平调整
 水平器

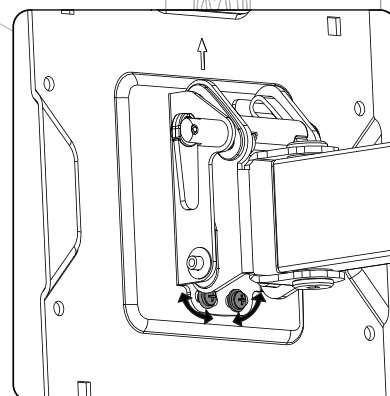
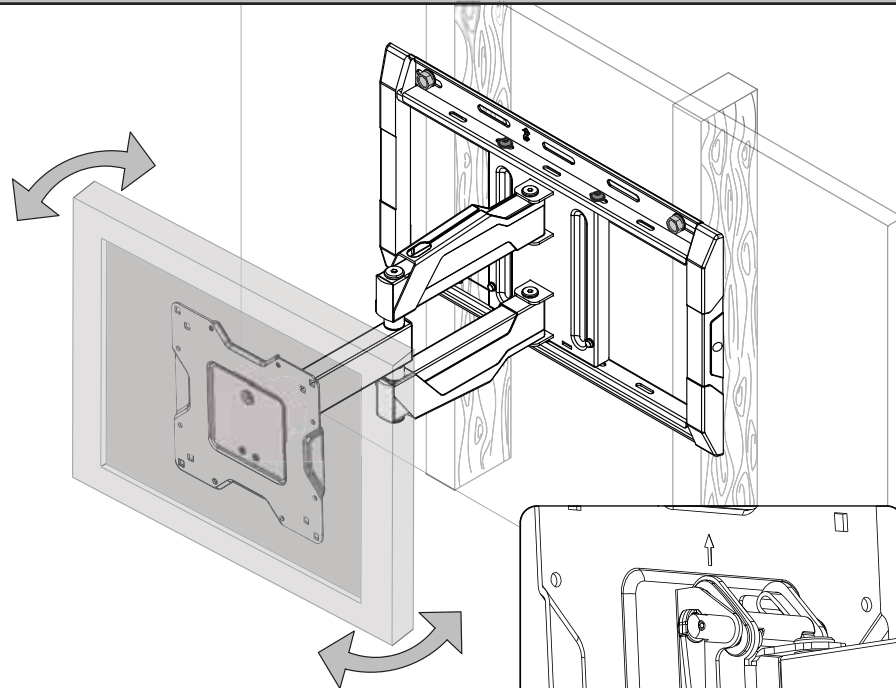

STEP 8 - ROUTE CABLES

Route Cables

Tienda los cables
Installez les câbles
Verlegen Sie die Kabel
Plaats de kabels
Inserire i cavi
Poprowadź kable
Natáhněte kabely
Vezesse el a kábeleket.
Δρομολόγηση καλωδίων
Dispor os cabos
Føringskabler
Reititã kaapelit
Lägg kablar
Direcționați cablurile
Маршрутни кабели
Suunake kaablid oma kohale
Virzienu kabeli
Kabelių išvedžiojimas
Napeljava kablov
Natiahnite káble
Укладка кабелей
Kabloları Düzenleyin
Før kablene
تالابكلا دي جوت
布线
ケーブルを配線します

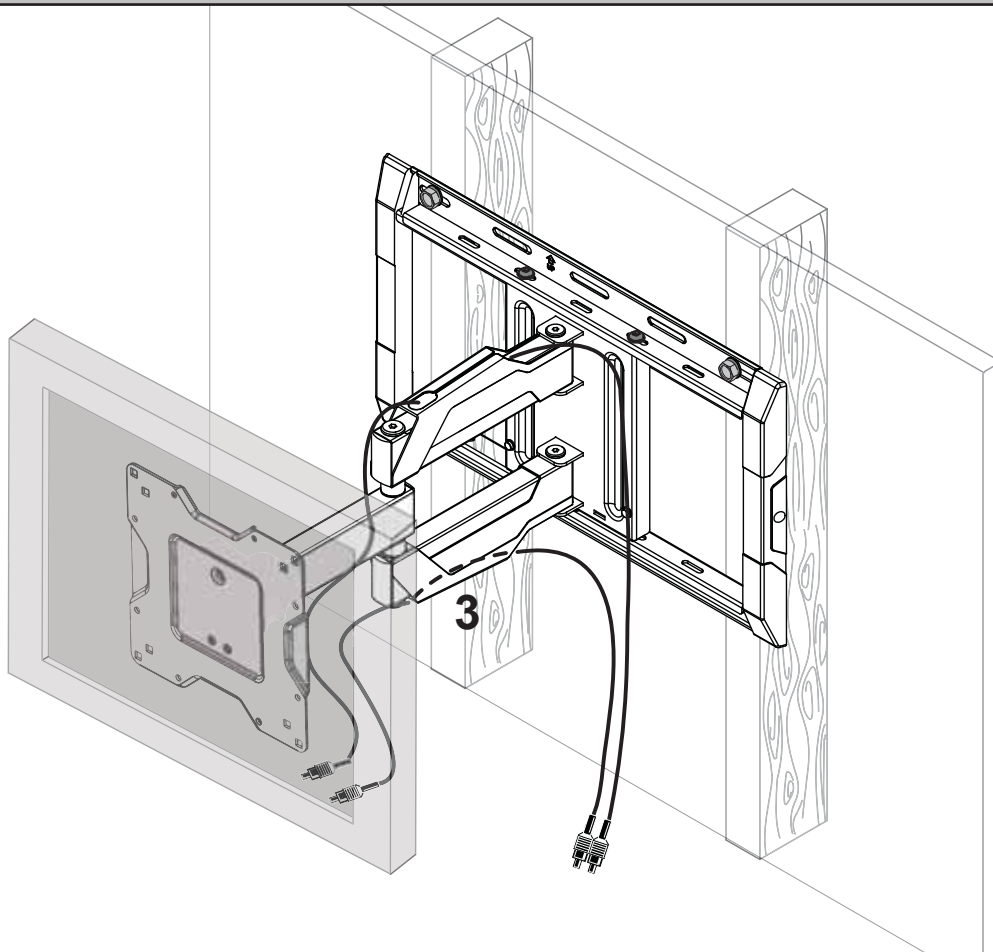

STEP 9 - ADJUST TILT TENSION

Adjust to Desired Location or Tilt

Ajuste a la inclinación o ubicación deseada
Ajustez à la position désirée ou inclinez
An die gewünschte Position anpassen oder neigen
Stel in op de gewenste plaats of kante
Regolare la posizione o l'inclinazione come desiderato
Dopasuj do żądanego położenia lub nachylenia
Upravte polohu tak, aby ste dosáhli požadovaného umístění nebo sklonu
Igazítsa a kívánt helyre vagy elforgatási helyzetbe.
Προσαρμογή στην επιθυμητή θέση ή κλίση
Ajustar ao local ou à inclinação desejada
Justér til ønsket placering eller vip
Sääda haluttuun kohtaan tai kulmaan
Justera till önskad position eller tippa
Reglați în poziția și la înclinația dorite
Регулируйте до желаната позиция или наклонете
Sättige soovitud asetus või kalle paika
Pielāgojiet nepieciešamajā stāvoklī vai slīpumā
Nustatykite norimą vietą arba pakreipimą
Prilagodite v ustrezen položaj ali nagib
Upravte polohu tak, aby ste dosiahli požadované umiestnenie alebo sklon
Отрегулируйте нужное положение и угол наклона
İstediginiz Pozisyona veya Eğime Ayarlayın
Juster til ønsket plassering eller skråstilling
بولنظما ليدلوا وعقولما ولأطبضل اب مو
調整到合适的位置或傾斜度
好みの位置または傾斜角度に調整します。

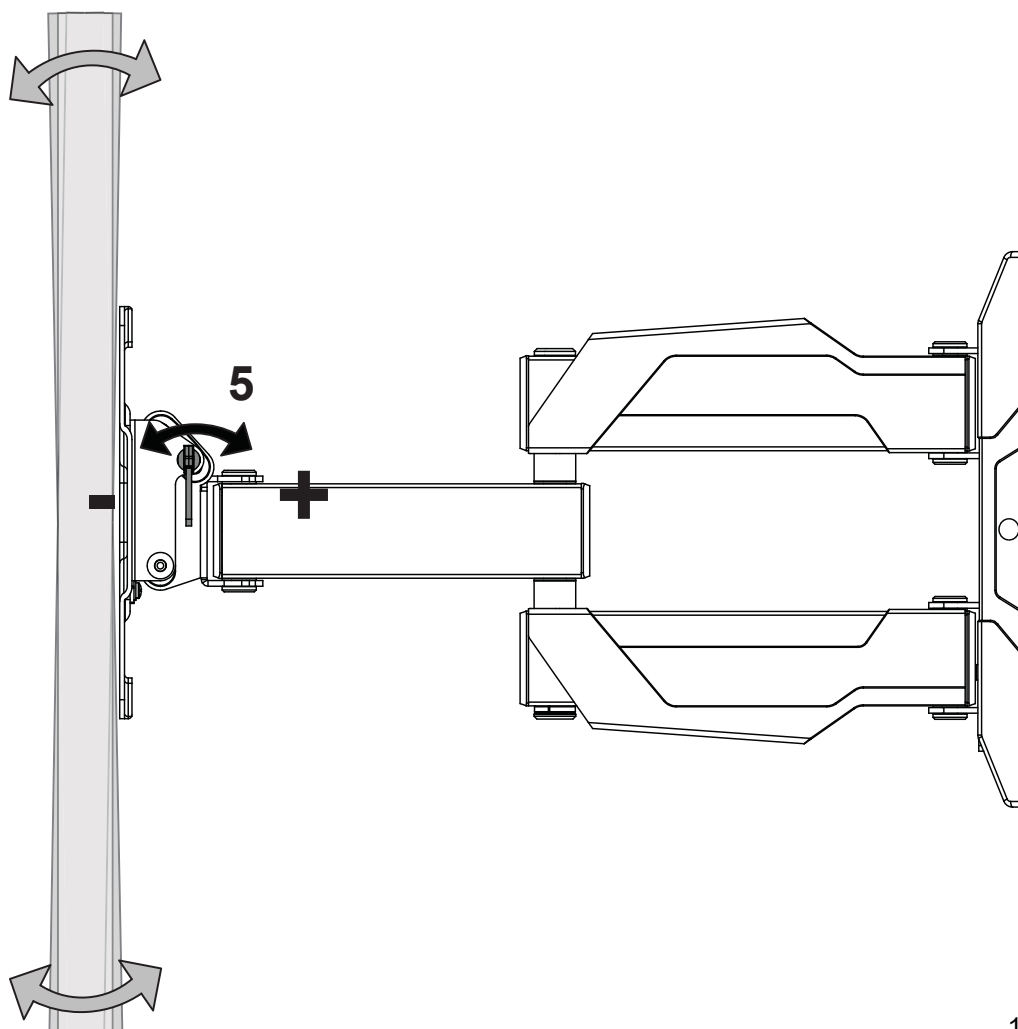



For the latest User Installation Guide please visit: www.ergotron.com

For Warranty visit: www.ergotron.com/warranty

For Service visit: www.ergotron.com

For local customer care phone numbers visit: <http://contact.ergotron.com>

www.ergotron.com | USA: 1-800-888-8458 | Europe: +31 (0)33-45 45 600 | China: 400-120-3051 | Japan: japansupport@ergotron.com

© 2011 Ergotron, Inc. All rights reserved.

While Ergotron, Inc. makes every effort to provide accurate and complete information on the installation and use of its products, it will not be held liable for any editorial errors or omissions (including those made in the process of translation from English to another language), or for incidental, special or consequential damages of any nature resulting from furnishing this instruction and performance of equipment in connection with this instruction. Ergotron, Inc. reserves the right to make changes in the product design and/or product documentation without notification to its users. For the most current product information, or to know if this document is available in languages other than those herein, please contact Ergotron. No part of this publication may be reproduced, stored in a retrieval system, or transmitted in any form or by any means, electronic, mechanical, photocopying, recording or otherwise without the prior written consent of Ergotron, Inc., 1181 Trapp Road, Eagan, Minnesota, 55121, USA Patents Pending and Patented U.S. & Foreign. Ergotron is a registered trademark of Ergotron, Inc.