

**OEM**

USER MANUAL

# TG2480H

Commands manual: **77200000001100**



CUSTOM ENGINEERING S.p.A.  
Str. Berettine 2  
43010 Fontevivo (PARMA) - Italy  
Tel. : +39 0521-680111  
Fax : +39 0521-610701  
http: www.custom.biz

Customer Service Department:  
Email : support@custom.it

© 2012 CUSTOM ENGINEERING S.p.A.  
– Italy. All rights reserved. Total or partial reproduction of this manual in whatever form, whether by printed or electronic means, is forbidden. While guaranteeing that the information contained in it has been carefully checked, CUSTOM ENGINEERING S.p.A. and other entities utilized in the realization of this manual bear no responsibility for how the manual is used. Information regarding any errors found in it or suggestions on how it could be improved are appreciated. Since products are subject to continuous check and improvement, CUSTOM ENGINEERING S.p.A. reserves the right to make changes in information contained in this manual without prior notification.

The pre-installed multimedia contents are protected from Copyright CUSTOM ENGINEERING. Other company and product names mentioned herein may be trademarks of their respective companies. Mention of third-party products is for informational purposes only and constitutes neither an endorsement nor a recommendation. CUSTOM ENGINEERING assumes no responsibility with regard to the performance or use of these products.

**THE IMAGES USED IN THIS MANUAL ARE USED AS AN ILLUSTRATIVE EXAMPLES. THEY COULDN'T REPRODUCE THE DESCRIBED MODEL FAITHFULLY.**

**UNLESS OTHERWISE SPECIFIED, THE INFORMATION GIVEN IN THIS MANUAL ARE REFERRED TO ALL MODELS IN PRODUCTION AT THE ISSUE DATE OF THIS DOCUMENT.**

#### GENERAL SAFETY INFORMATION

Your attention is drawn to the following actions that could compromise the characteristics of the product:

- Read and retain the instructions which follow.
- Follow all indications and instructions given on the device.
- Make sure that the surface on which the device rests is stable. If it is not, the device could fall, seriously damaging it.
- Make sure that the device rests on a hard (non-padded) surface and that there is sufficient ventilation.
- When positioning the device, make sure cables do not get damaged.
- Use the type of electrical power supply indicated on the device label. If uncertain, contact your dealer.
- Make sure the electrical system that supplies power to the device is equipped with a ground wire and is protected by a differential switch.
- Do not block the ventilation openings.
- Do not insert objects inside the device as this could cause short-circuiting or damage components that could jeopardize printer functioning.
- Do not carry out repairs on the device yourself, except for the normal maintenance operations given in the user manual.
- Make sure that there is an easily-accessible outlet with a capacity of no less than 15A in the vicinity of where the device is to be installed.
- Periodically perform scheduled maintenance on the device to avoid dirt build-up that could compromise the correct, safe operation of the unit.
- Before any type of work is done on the machine, disconnect the power supply.
- Do not touch the head heating line with bare hands or metal objects. Do not perform any operation inside the printer immediately after printing because the head and motor tend to become very hot.

#### GENERAL INSTRUCTIONS

CUSTOM ENGINEERING S.p.A. declines all responsibility for accidents or damage to persons or property occurring as a result of tampering, structural or functional modifications, unsuitable or incorrect installations, environments not in keeping with the equipment's protection degree or with the required temperature and humidity conditions, failure to carry out maintenance and periodical inspections and poor repair work.



THE CE MARK AFFIXED TO THE PRODUCT CERTIFY THAT THE PRODUCT SATISFIES THE BASIC SAFETY REQUIREMENTS.

The device is in conformity with the essential Electromagnetic Compatibility and Electric Safety requirements laid down in Directives 2006/95/CE and 2004/108/CE inasmuch as it was designed in conformity with the provisions laid down in the following Standards:

- EN 55022 Class B (*Limits and methods of measurements of radio disturbance characteristics of Information Technology Equipment*)
- EN 55024 (*Information Technology Equipment – Immunity characteristics – Limits and methods of measurement*)
- EN 60950 (*Safety of information equipment including electrical business equipment*)



GUIDELINES FOR THE DISPOSAL OF THE PRODUCT

The crossed-out rubbish bin logo means that used electrical and electronic products shall NOT be mixed with unsorted municipal waste. For more detailed information about recycling of this product, refer to the instructions of your country for the disposal of these products.

- Do not dispose of this equipment as miscellaneous solid municipal waste, but arrange to have it collected separately.
- The re-use or correct recycling of the electronic and electrical equipment (EEE) is important in order to protect the environment and the wellbeing of humans.
- In accordance with European Directive WEEE 2002/96/EC, special collection points are available to which to deliver waste electrical and electronic equipment and the equipment can also be handed over to a distributor at the moment of purchasing a new equivalent type.
- The public administration and producers of electrical and electronic equipment are involved in facilitating the processes of the re-use and recovery of waste electrical and electronic equipment through the organisation of collection activities and the use of appropriate planning arrangements.
- Unauthorised disposal of waste electrical and electronic equipment is punishable by law with the appropriate penalties.



The format used for this manual improves use of natural resources reducing the quantity of necessary paper to print this copy.



# TABLE OF CONTENTS

<b>1 INTRODUCTION</b> .....	<b>7</b>
1.1 Document structure .....	7
1.2 Explanatory notes used in this manual.....	7
<b>2 DESCRIPTION</b> .....	<b>9</b>
2.1 Unpacking the printer .....	9
2.2 Printer components .....	10
2.3 Key functions.....	12
2.4 Status led flashes .....	14
<b>3 INSTALLATION</b> .....	<b>15</b>
3.1 Fastening.....	15
3.2 Positioning paper roll holder support.....	16
3.3 Connections .....	17
3.4 Pinout .....	18
3.5 Driver.....	20
<b>4 OPERATION</b> .....	<b>21</b>
4.1 Open the printer .....	21
4.2 Adjustment for paper roll holder support .....	22
4.3 Paper roll insertion .....	23
4.4 Ticket withdrawal sensor .....	24
<b>5 CONFIGURATION</b> .....	<b>25</b>
5.1 Configuration mode .....	25
5.2 Setup report.....	27
5.3 Printer status .....	28
5.4 Printer parameters.....	29
5.5 Hexadecimal dump.....	32
<b>6 MAINTENANCE</b> .....	<b>33</b>
6.1 Paper jam .....	33
6.2 Planning of cleaning operations .....	34
6.3 Cleaning .....	35
6.4 Upgrade firmware.....	38
<b>7 SPECIFICATIONS</b> .....	<b>41</b>
7.1 Hardware specifications .....	41
7.2 Character specifications .....	43
7.3 Printer dimensions.....	43
7.4 Power supply dimensions cod. 964GE010000362 (optional).....	45
7.5 Paper specifications with notch alignment .....	46
7.6 Standard character sets .....	47
<b>8 CONSUMABLES</b> .....	<b>55</b>
<b>9 ACCESSORIES</b> .....	<b>57</b>
<b>10 ALIGNMENT</b> .....	<b>59</b>
10.1 Enable alignment.....	59

## TABLE OF CONTENTS

---

10.2 Calibration .....	59
10.3 Alignment parameters .....	61
10.4 Printing area .....	64
<b>11 TECHNICAL SERVICE .....</b>	<b>65</b>

# 1 INTRODUCTION

## 1.1 Document structure

This document includes the following chapters:

1	INTRODUCTION	information about this document
2	DESCRIPTION	general description of device
3	INSTALLATION	information required for a correct installation of the device
4	OPERATION	information required to make the device operative
5	CONFIGURATION	description of the configuration parameters of the device
6	MAINTENANCE	information for a correct periodic maintenance
7	SPECIFICATION	technical specification for the device and its accessories
8	ACCESSORIES	description and installation of the available accessories for the device
9	CONSUMABLES	description and installation of the available consumables for the device
10	ALIGNMENT	information required for managing the paper alignment
11	TECHNICAL SERVICE	information required for contacting the technical service

## 1.2 Explanatory notes used in this manual

**NOTE:** Information or suggestions relative to the use of the printer.

**ATTENTION:** Information required to guard against damaging the printer.

**DANGER:** Information required to guard against operator injury or damage.





## 2 DESCRIPTION

### 2.1 Unpacking the printer

Remove the printer from its carton being careful not to damage the packing material so that it may be re-used if the printer is to be transported in the future. Make sure that all the components illustrated below are present and that there are no signs of damage. If there are, contact Customer Service.

- |                              |                             |
|------------------------------|-----------------------------|
| 1. Installation instructions | 4. Printer                  |
| 2. Paper roll                | 5. Protection packing shell |
| 3. Power supply cable        | 6. Box                      |

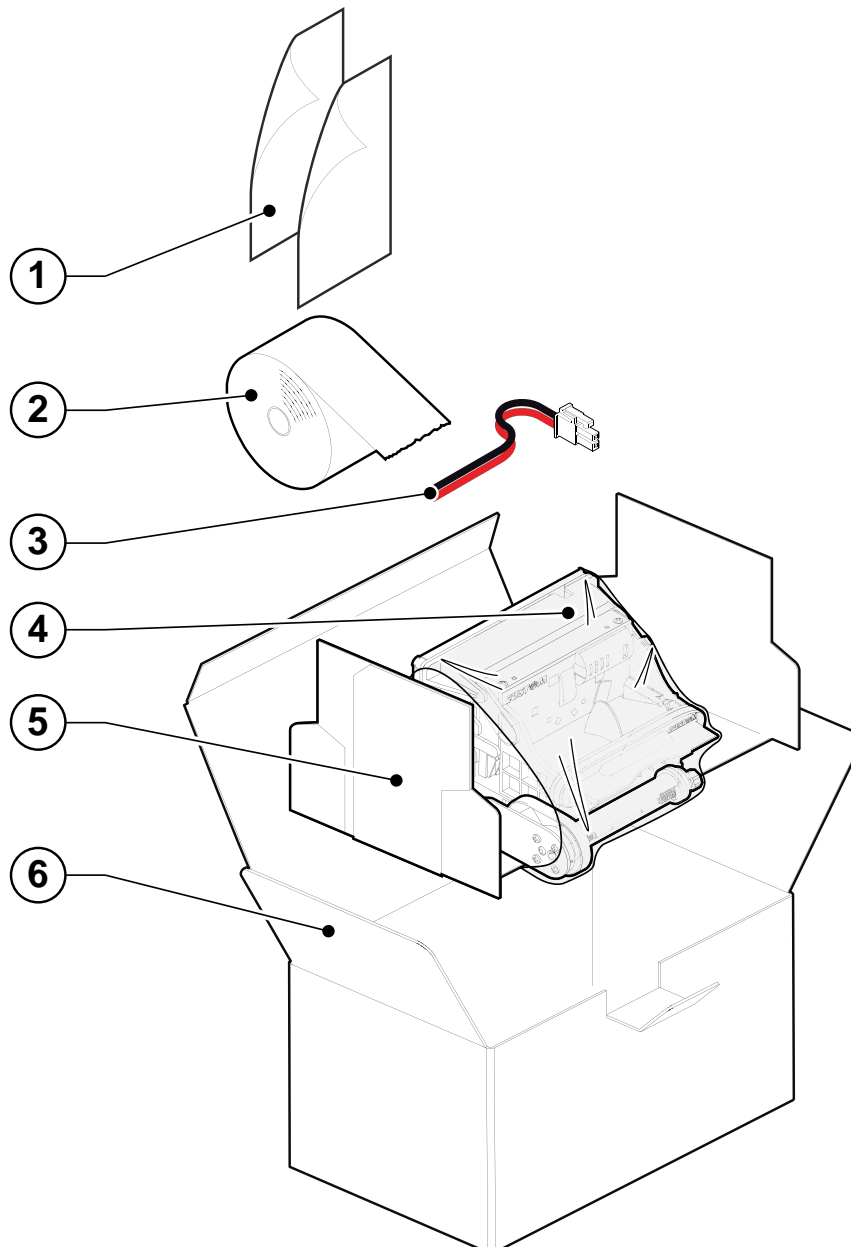

- Open the printer packaging
- Take out the paper roll.
- Take out the user manual and the installation instructions.
- Take out the power supply cable.
- Lift the protection packing shell and take out the printer.
- Keep the box packing materials in the event the printer must be transported/shipped in the future.

## 2. DESCRIPTION

### 2.2 Printer components

#### EXTERNAL VIEWS

- |                                       |                                     |
|---------------------------------------|-------------------------------------|
| 1. Near paper end sensor              | 11. Metal chassis                   |
| 2. Paper roll holder support          | 12. Cutter group                    |
| 3. Paper width adjustment             | 13. Print head                      |
| 4. Near paper end sensor adjustment   | 14. Inspection door                 |
| 5. Unblocking lever for cutter unit   | 15. Paper mouth                     |
| 6. Rubbed roller manual feed          | 16. Ticket withdrawal sensor        |
| 7. Unblocking lever for rubbed roller | 17. Status LED                      |
| 8. PRINT key                          | 18. Paper in                        |
| 9. FEED key                           | 19. Paper presence and notch sensor |
| 10. Paper jam sensor                  |                                     |

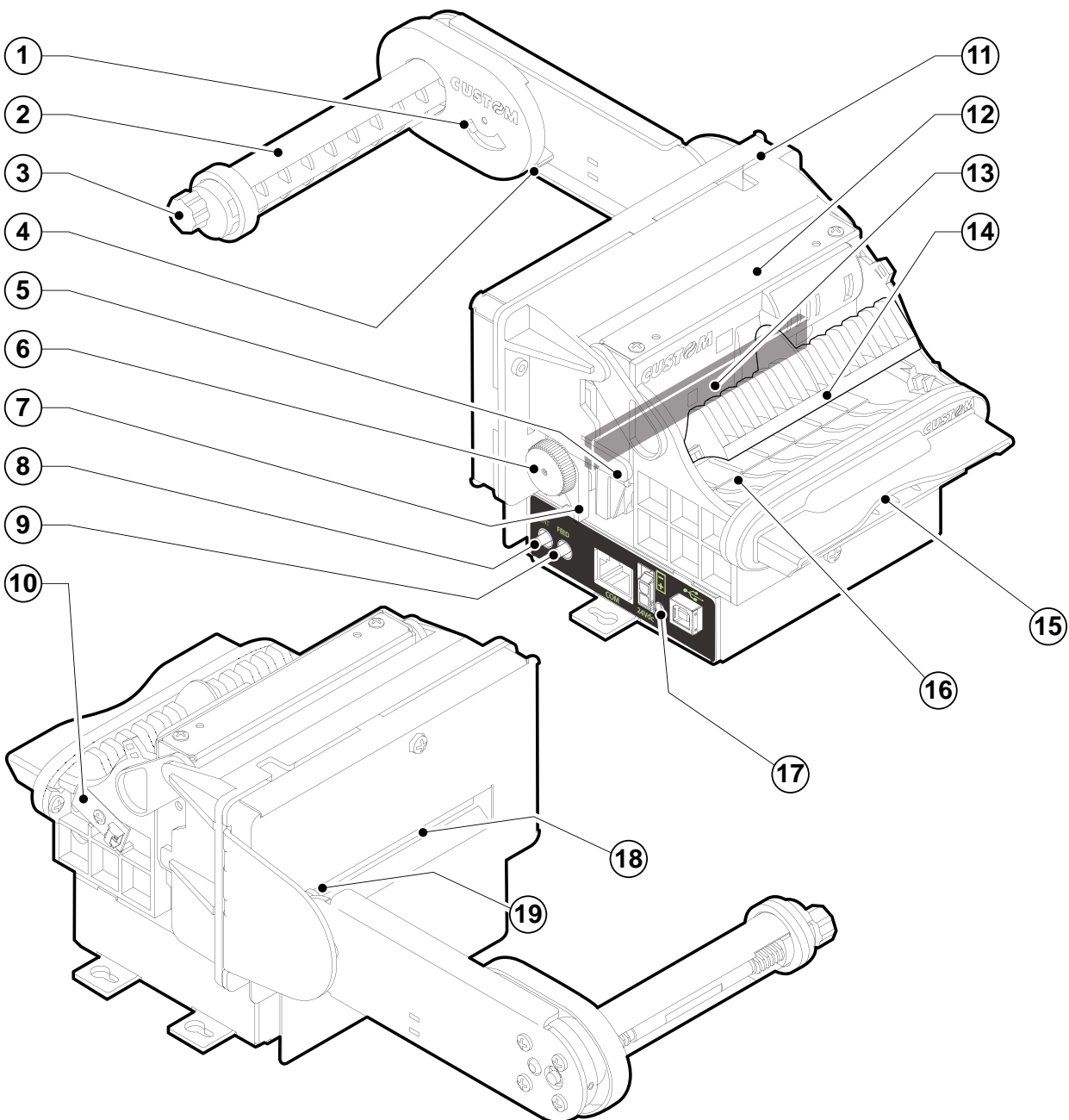

**EXTERNAL CONNECTORS VIEW**

1. USB connector
2. Power supply connector
3. RS232 connector

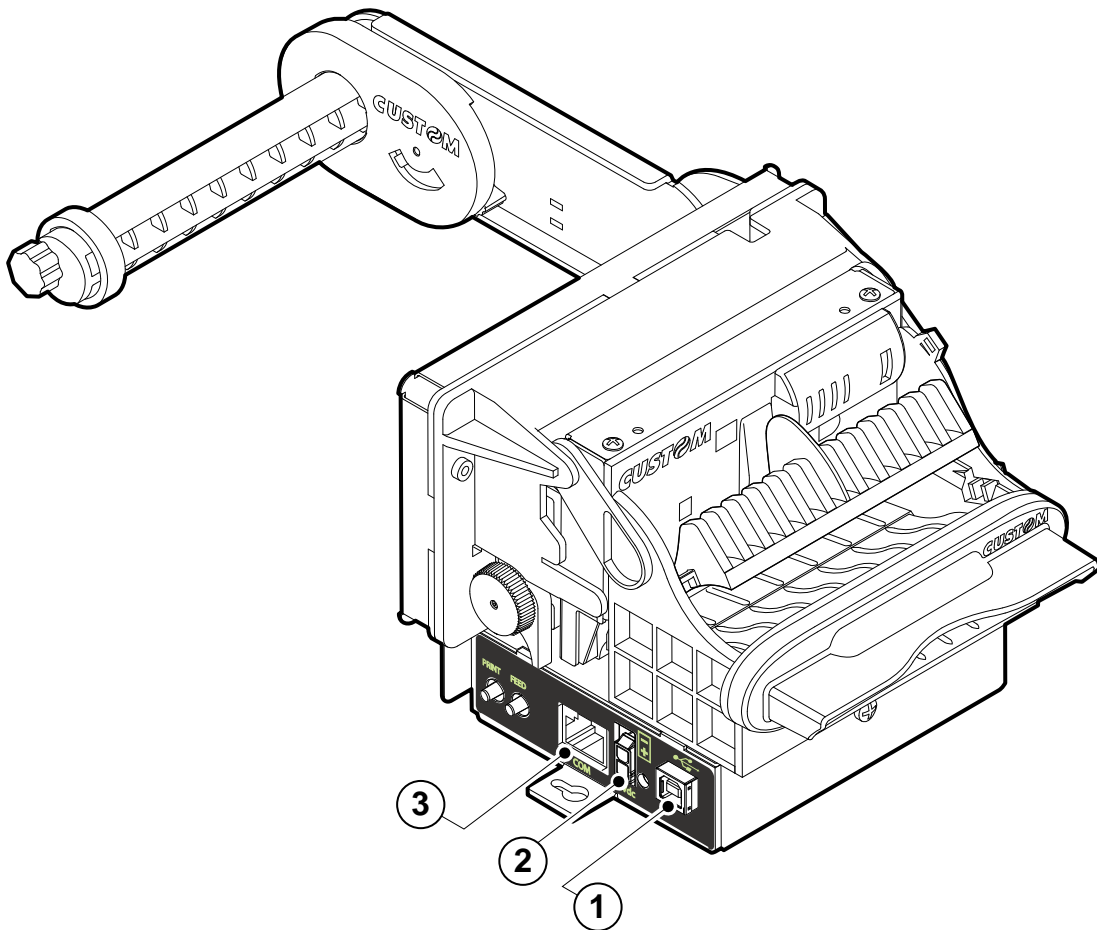

## 2. DESCRIPTION

### 2.3 Key functions

The following figures show the functions of printer's keys according to the operating condition of the device.

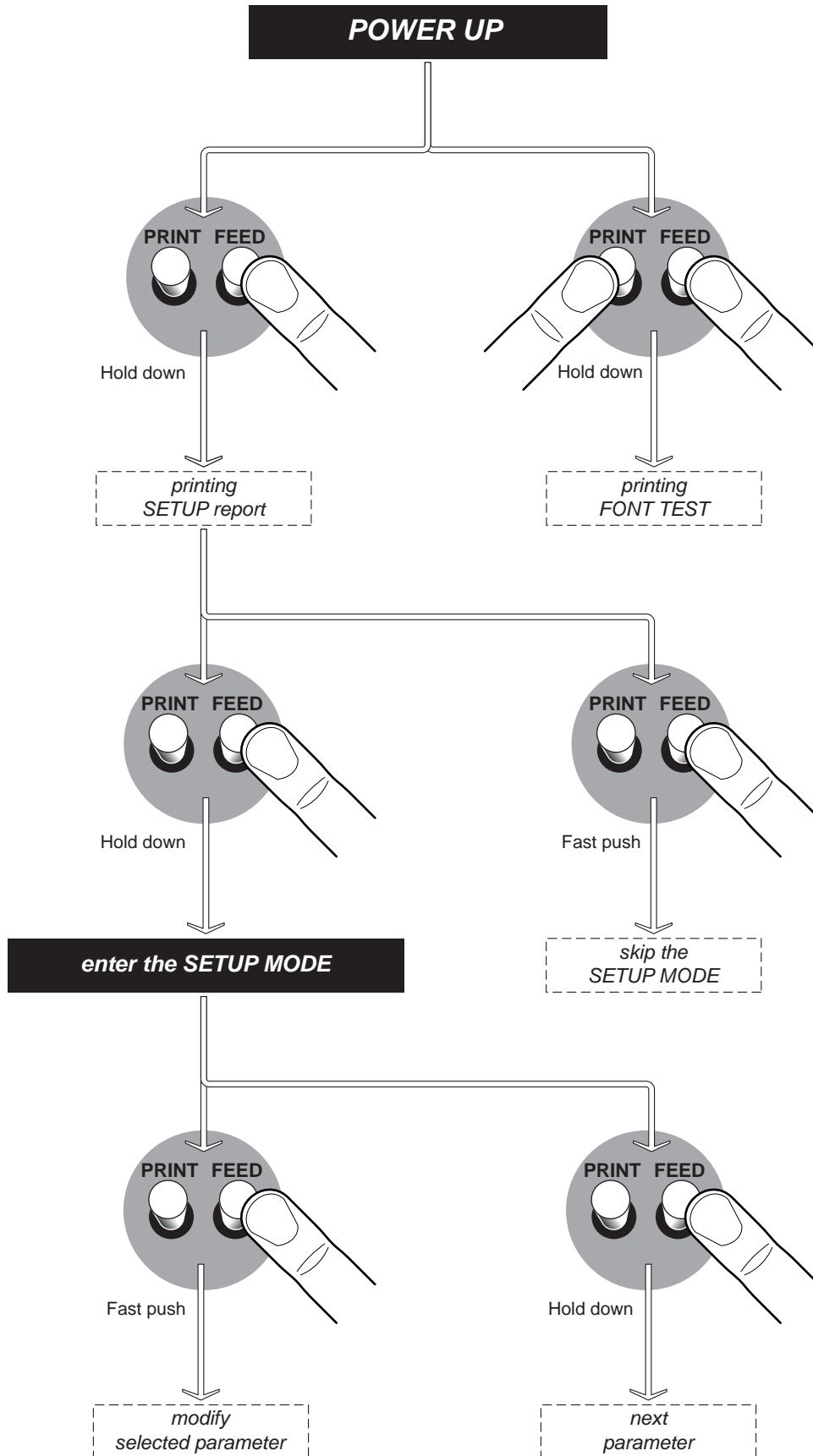

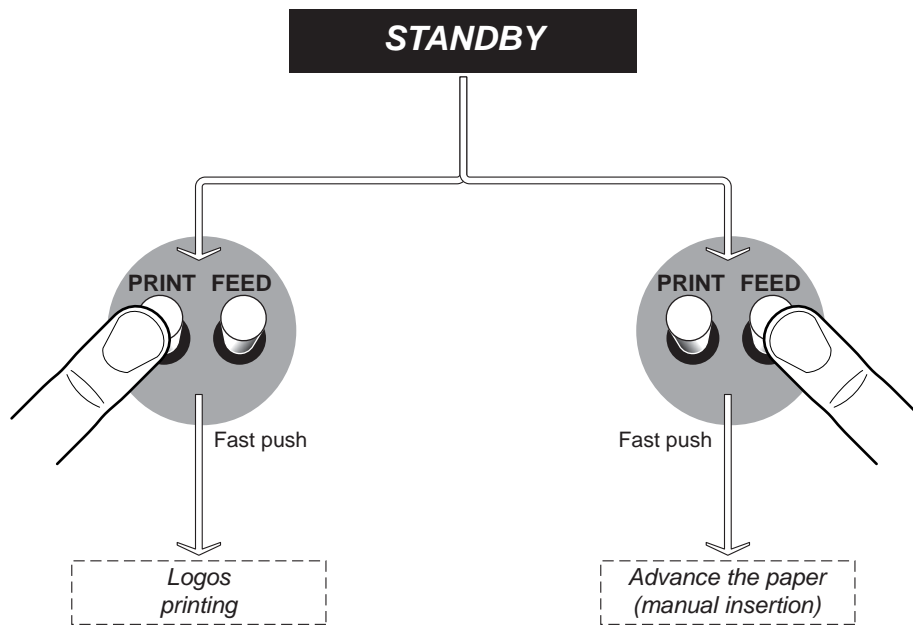





## 2. DESCRIPTION

### 2.4 Status led flashes

The Status led indicates hardware status of device. Given in the table below are the various led signals and the corresponding printer status.

STATUS LED		DESCRIPTION	
-		<b>OFF</b>	PRINTER OFF
GREEN		<b>ON</b>	PRINTER ON: NO ERROR
GREEN RECOVERABLE ERROR		<b>1 x</b>	RECEIVE DATA
		<b>2 x</b>	HEADING OVER TEMPERATURE
		<b>3 x</b>	PAPER END
		<b>4 x</b>	POWER SUPPLY VOLTAGE INCORRECT
		<b>5 x</b>	RECEPTION ERRORS (PARITY, FRAME ERROR, OVERRUN ERROR)
		<b>6 x</b>	COMMAND NOT RECOGNIZED
		<b>7 x</b>	COMMAND RECEPTION TIME OUT
		<b>8 x</b>	ROTATING COVER OPEN
		<b>9 x</b>	PAPER JAM
		<b>10 x</b>	NEAR PAPER END
GREEN UNRECOVERABLE ERROR		<b>11 x</b>	CUTTER ERROR

## 3 INSTALLATION

### 3.1 Fastening

The printer is provided with three fixing holes on the bottom of device (see following figure). To fasten the printer on a panel, use three M3 screws

Dimensions in mm:

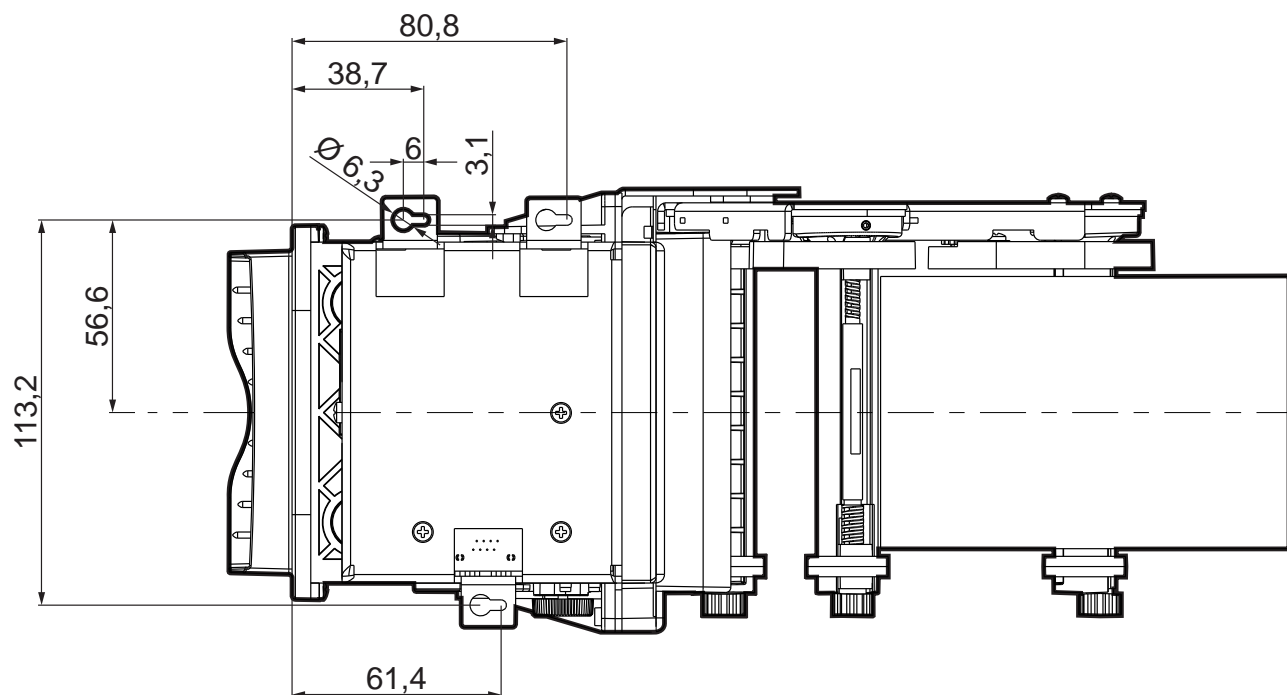

**ATTENTION:**

During the integration of the device, we strongly warn to keep an adequate paper loop outlet underneath the presenter, in order to allow the receipt being properly printed out.

## 3. INSTALLATION

### 3.2 Positioning paper roll holder support

The paper roll holder support position is adjustable on three different positions, according to the requirements of use of the device:

P1 = rear position

P2 = 45 degrees low position

P3 = upper position

#### ATTENTION:

Before fastening the paper roll holder support check the cable path (near paper end sensor) is correct. Incorrect positions of the cable could cause damage on it.

Fix the roll holder to the printer using the two M4x6 screws supplied (see following figures).

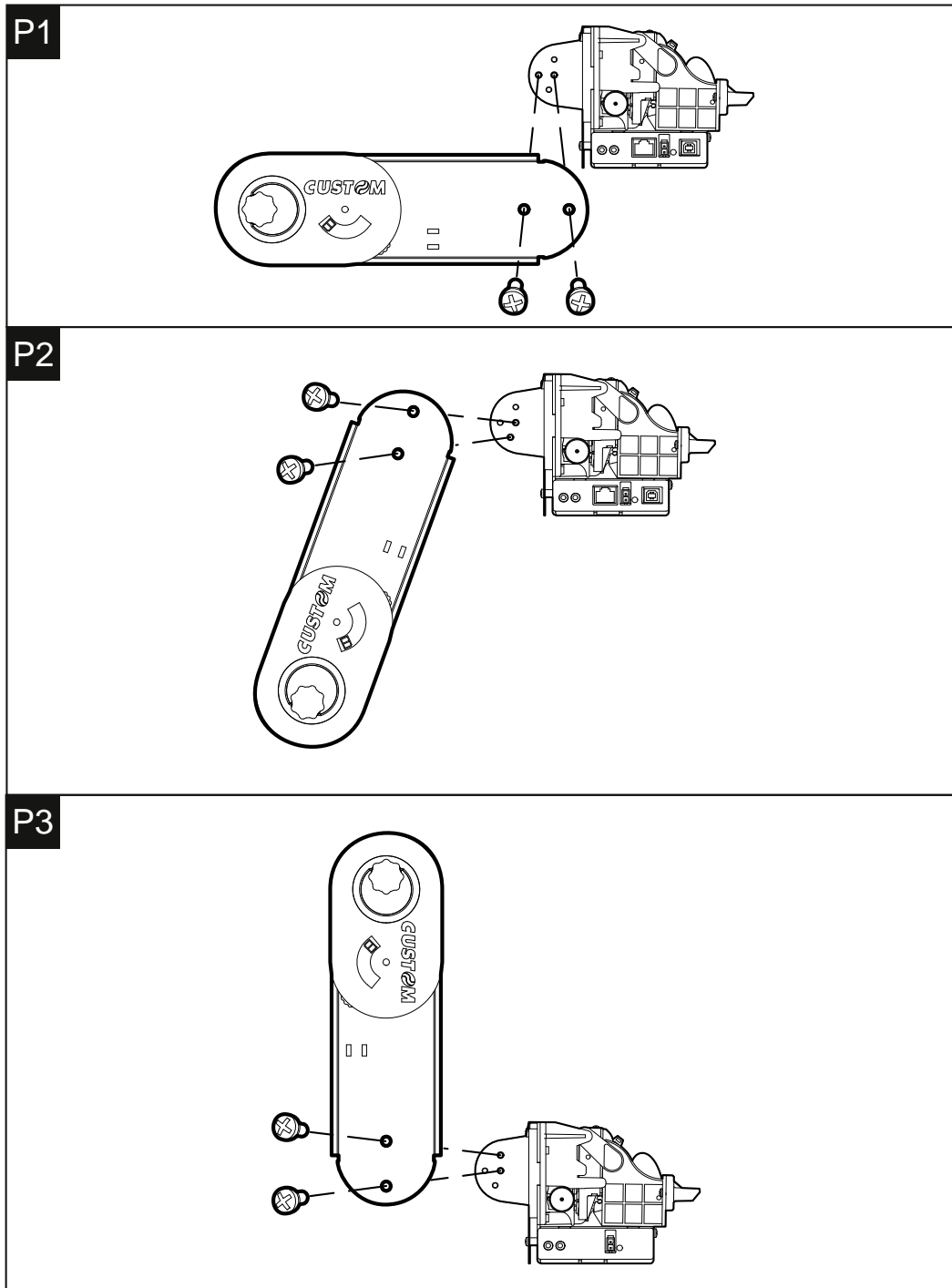



### 3.3 Connections

The following figure shows the possible connections for device.

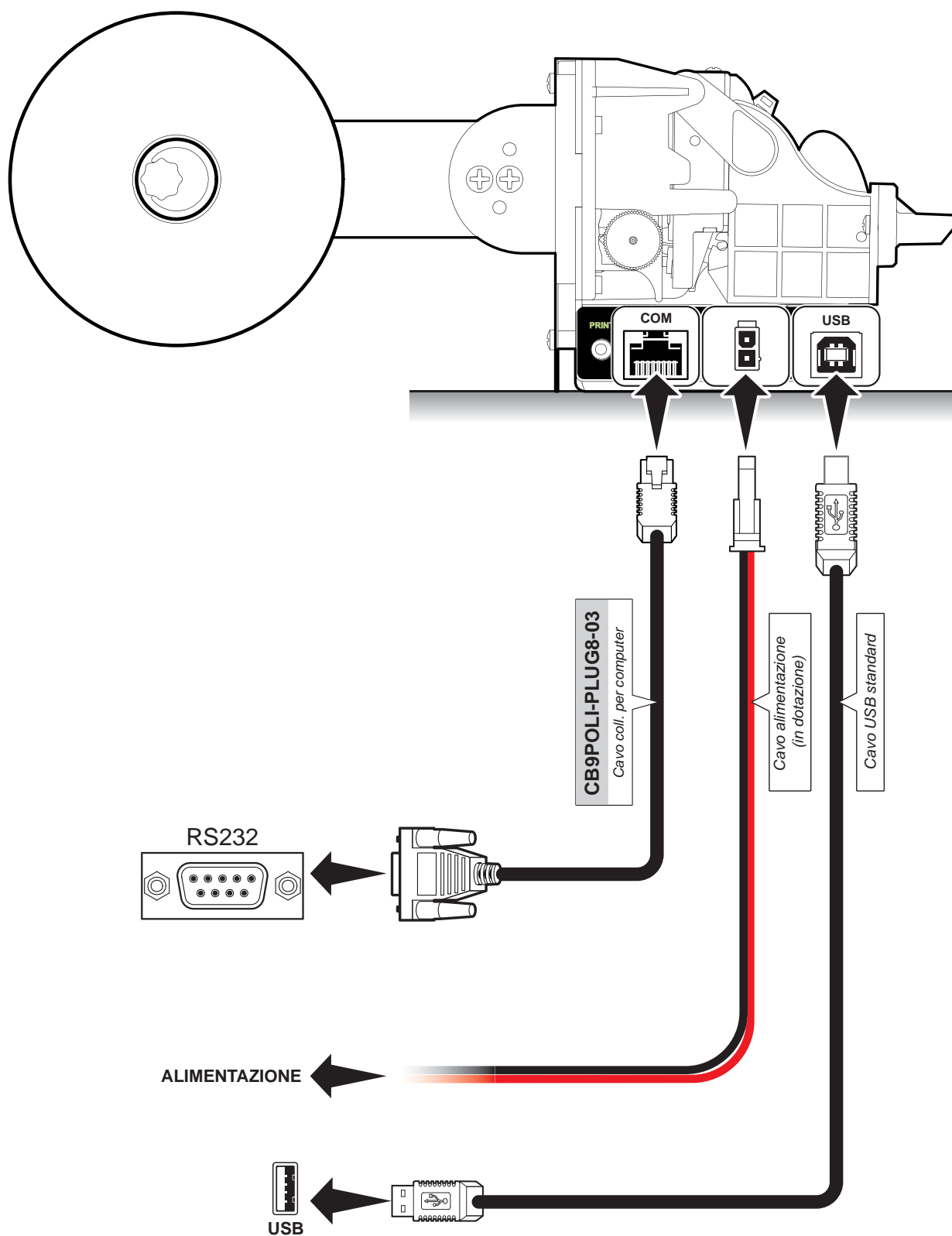

**ATTENTION:**

In some using conditions, we recommend the installation of a ferrite core on the power supply cable.

**NOTE:** If RS232 and USB connectors are inserted, communication port is USB.

### 3. INSTALLATION

#### 3.4 Pinout



#### POWER SUPPLY

Male Molex connector series 5569 vertical (no. 39-30-1020)

J14	1	+24 Vdc
	2	GND

#### ATTENTION:

Respect power supply polarity.

#### Note: Power supply cable

The following figure shows the connector pinout of the power supply cable for the device:

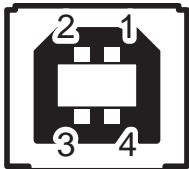
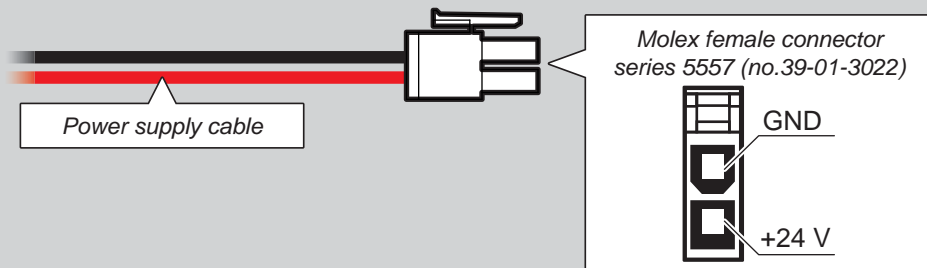

#### USB INTERFACE

Female USB type B connector

J1	1	USB-ON	(in)
	2	D0 -	(in/out)
	3	D0 +	(in/out)
	4	GND	
	SH1	SHIELD	
	SH2	SHIELD	

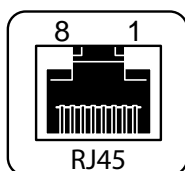

## RS232 SERIAL INTERFACE

Female RJ45 connector

Pin	Signal	Description
1	n.c.	
2	GND	
3	TX	During transmission, takes the value "0" and "1", depending on data
4	RX	During reception, takes the value "0" and "1", depending on data
5	RTS	When "1", printer is ready to receive data
6	n.c.	
7	n.c.	
8	n.c.	

**Note:** Given the presence of the RS232 standard, logic value "0" corresponds to a voltage level of between +3 Vdc and +15 Vdc and logic value "1" corresponds to a voltage level of between -3 Vdc and -15 Vdc.

### Note: TG2480H > PC connection

The following pictures show an example of connections between the printer and a personal computer using a 9 pin female serial connectors:

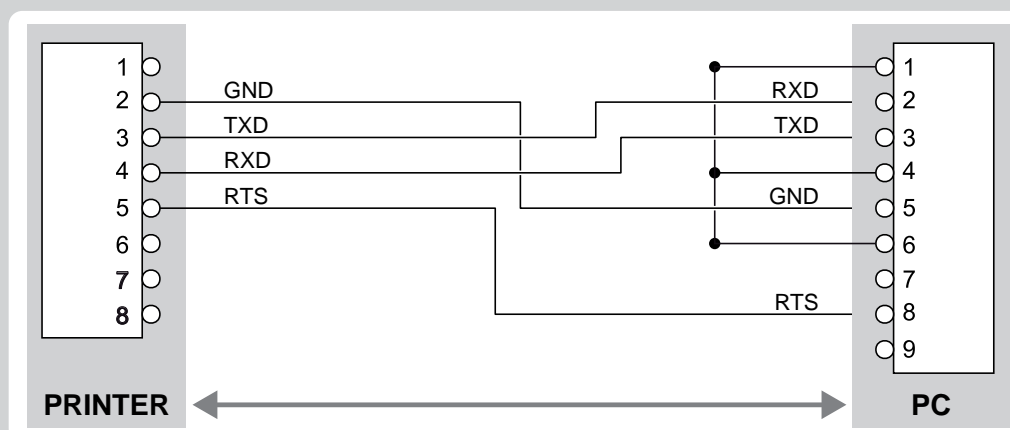

### 3. INSTALLATION

---

#### 3.5 Driver

The drivers are available for the following operating system:

OPERATING SYSTEM	DRIVER	INSTALLATION PROCEDURE
Windows	Windows XP	From the START menu, press Enter and key-in the path where the SW was saved on your PC, then click OK. Follow the instructions that appear on the screen to install the driver.
	Windows VISTA (32/64bit)	
	Windows 7 (32/64bit)	
	OPOS	
Linux		Follow the instruction get back on the README.TXT file you can find it in the software package downloaded in advance.

All drivers can be found in the DOWNLOAD section of the web site [www.custom.biz](http://www.custom.biz).

## 4 OPERATION

### 4.1 Open the printer

To open the printer proceed as follow:

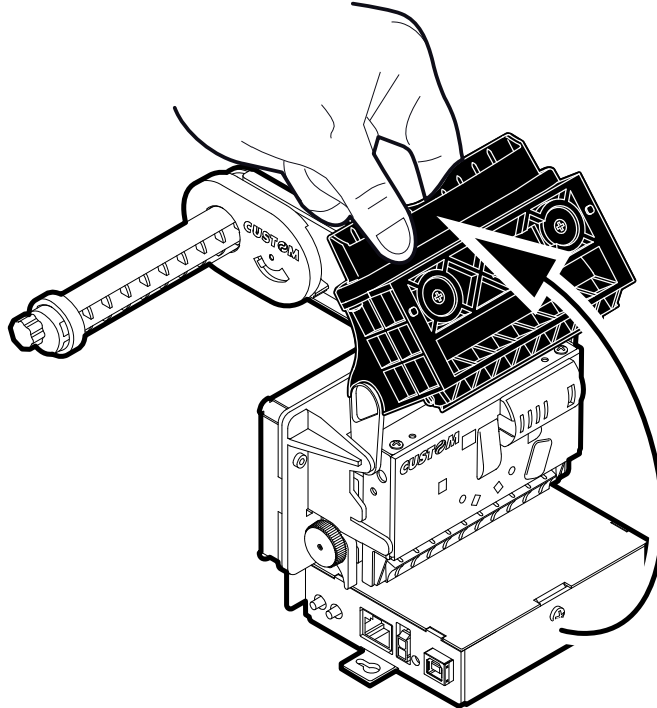
**1**

Rotate the paper mouth unit to the maximum opening position.  
In this position the paper mouth unit stay opened.

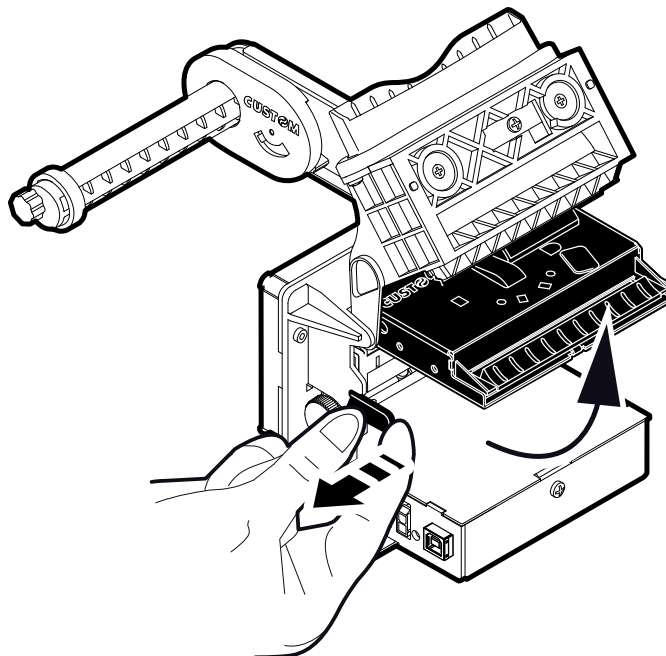
**2**

Widen the hooks that block the cutter unit and rotate the cutter unit up.

**NOTE:**

After each maintenance operation is recommended to check and remove possible scraps of paper.

## 4. OPERATION

### 4.2 Adjustment for paper roll holder support

To adjust the paper roll holder support proceed as follows:

1

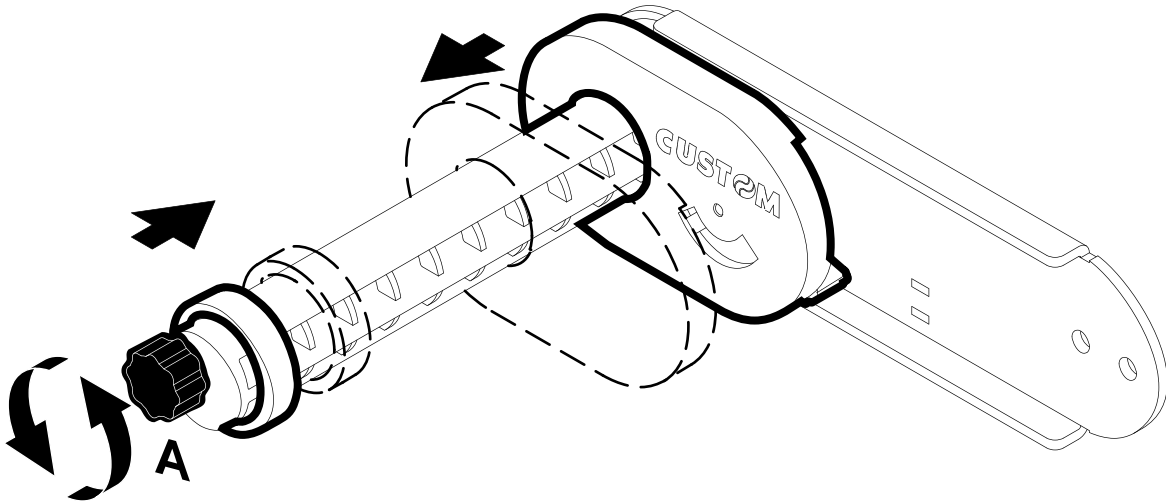

Rotate the knob (A) to adjust the housing width for paper roll.  
So it is possible to use paper width less than 80 mm as needed.

2

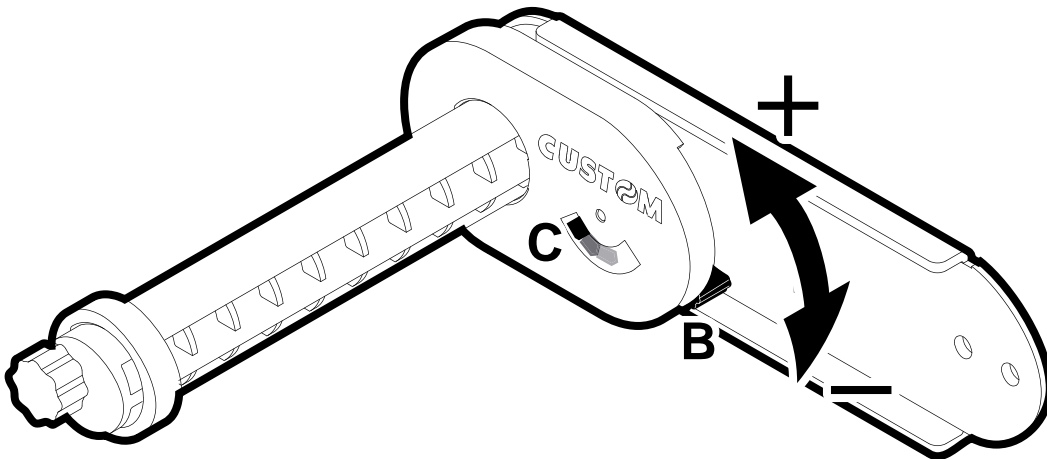

Rotate the lever (B) to adjust the sensor position for nearly paper end (C). Move the lever up to increase the reserve of paper, move the lever down to decrease the reserve of paper.

### 4.3 Paper roll insertion

To change the paper roll proceed as follows:

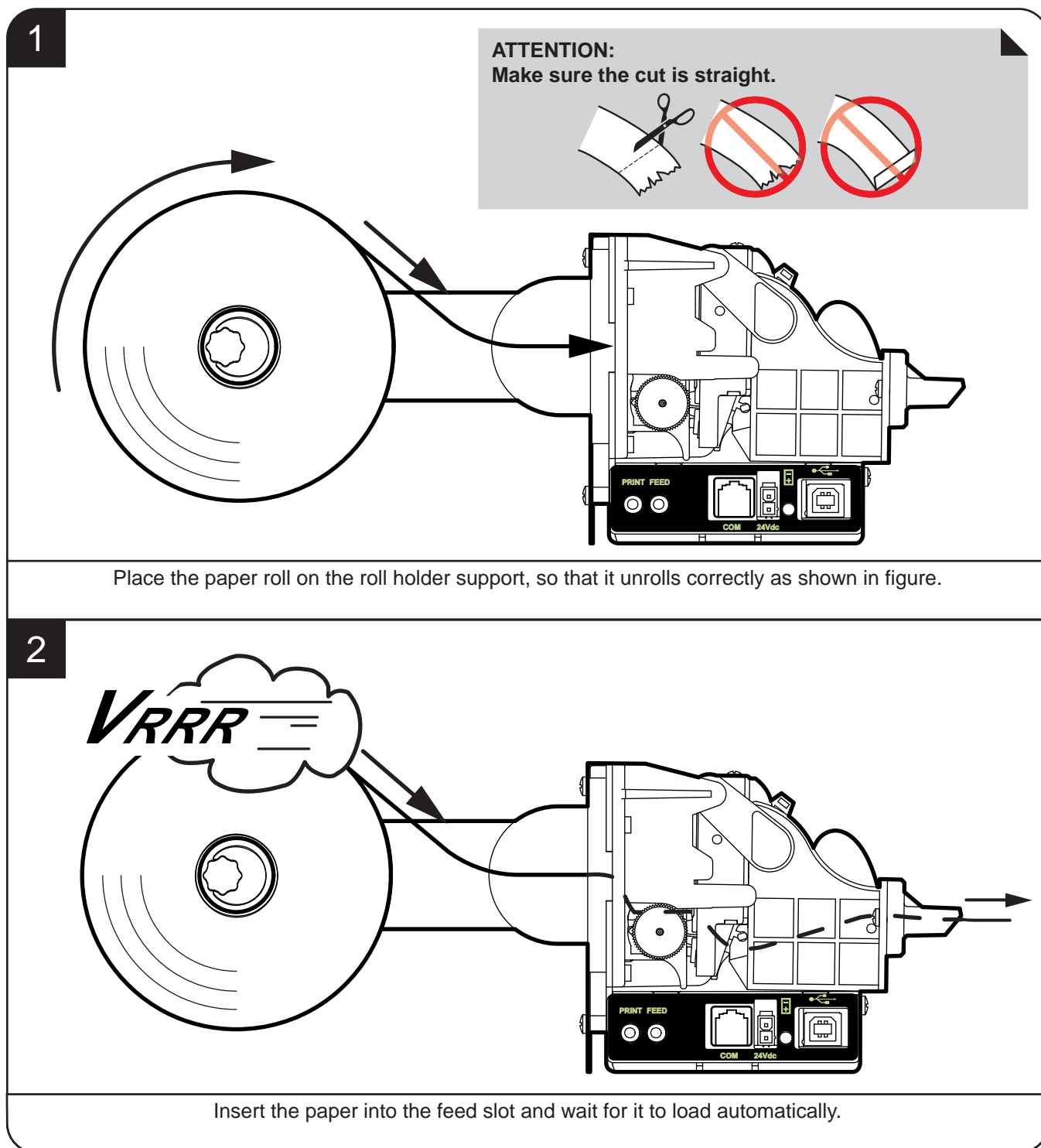

**Note:** At every change of paper roll, check inside the printer and remove any scraps of paper and accumulated dust (see par.6.2).

## 4. OPERATION

---

### 4.4 Ticket withdrawal sensor

The printer is equipped with a paper dispense restriction device to prevent damage on the printing mechanism in case of ticket withdrawal before the printing is end. This device is composed of an oscillating plane under the inspection door, linked with a sensor.

When the user make a ticket withdrawal before the printing is end, the ticket stretch causing the lowering of the oscillating plane. Ticket printing immediately stops, and the printer perform the ticket cut.

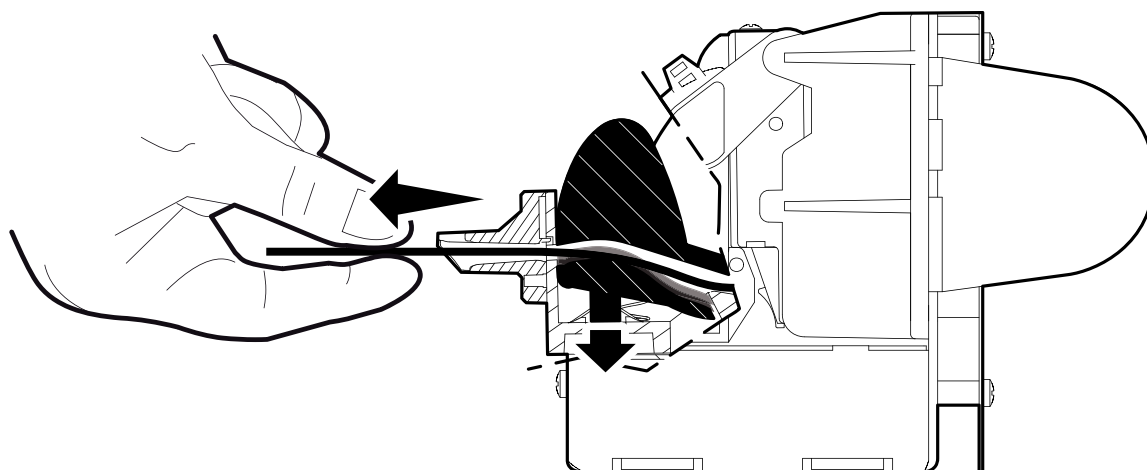



## 5 CONFIGURATION

### 5.1 Configuration mode

To enter the configuration mode and print a SETUP report with the operating parameters of the printer, proceed as follows.

1

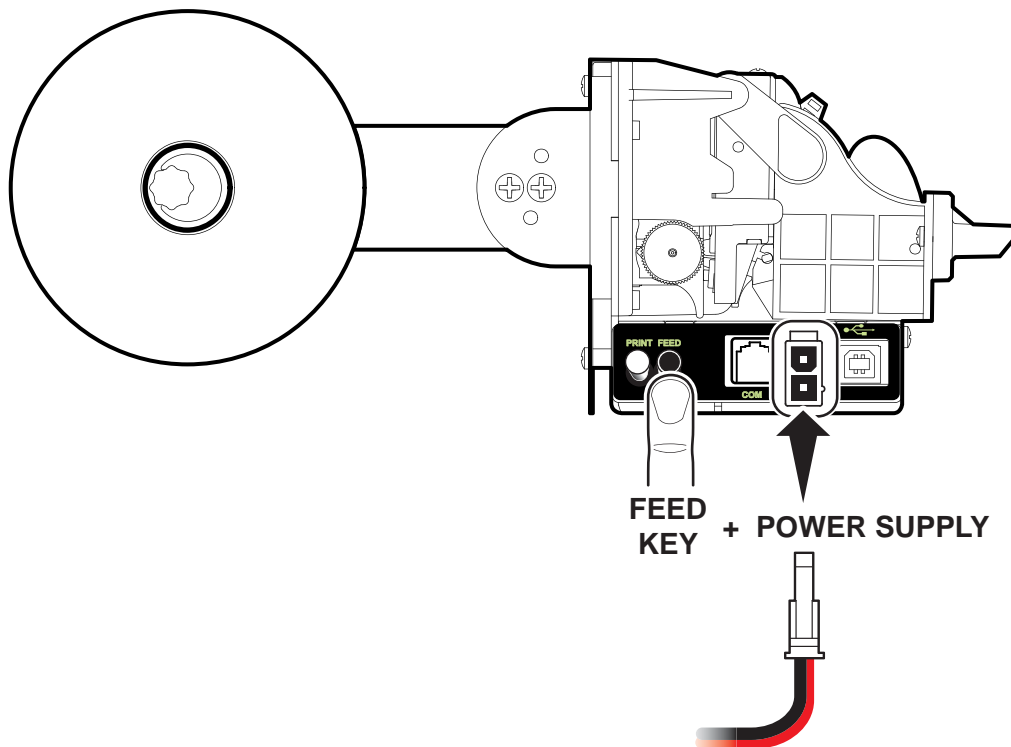

During power-up, hold down the FEED key while the wiring is plugged into the power supply connector of the printer.

2

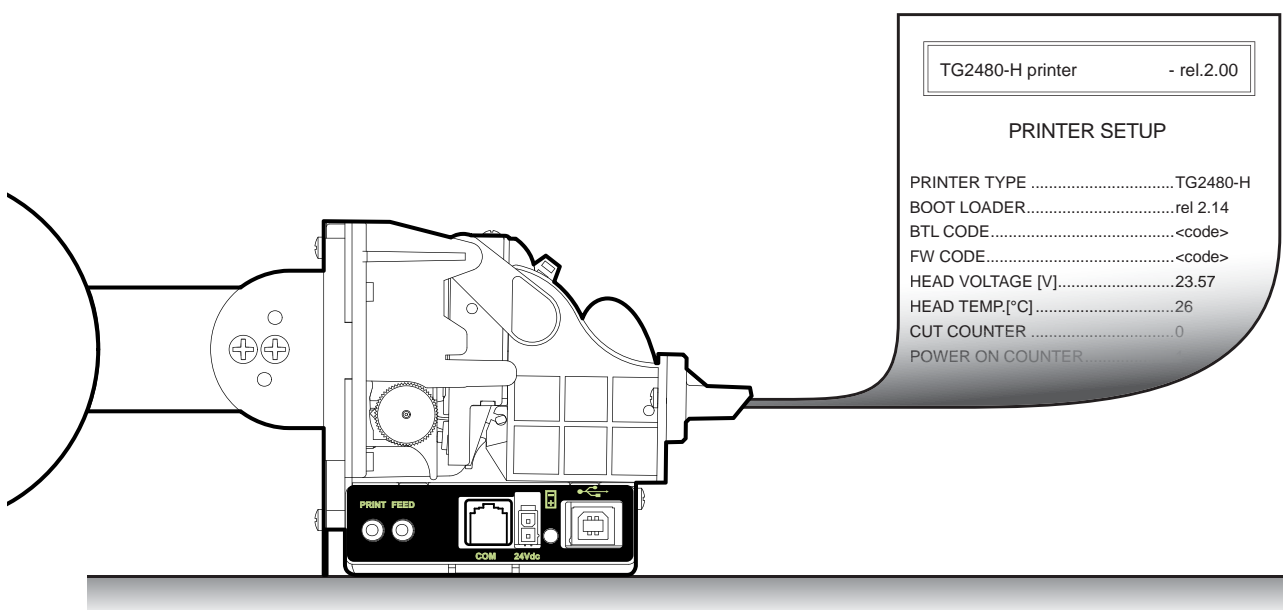

The device prints a SETUP report.

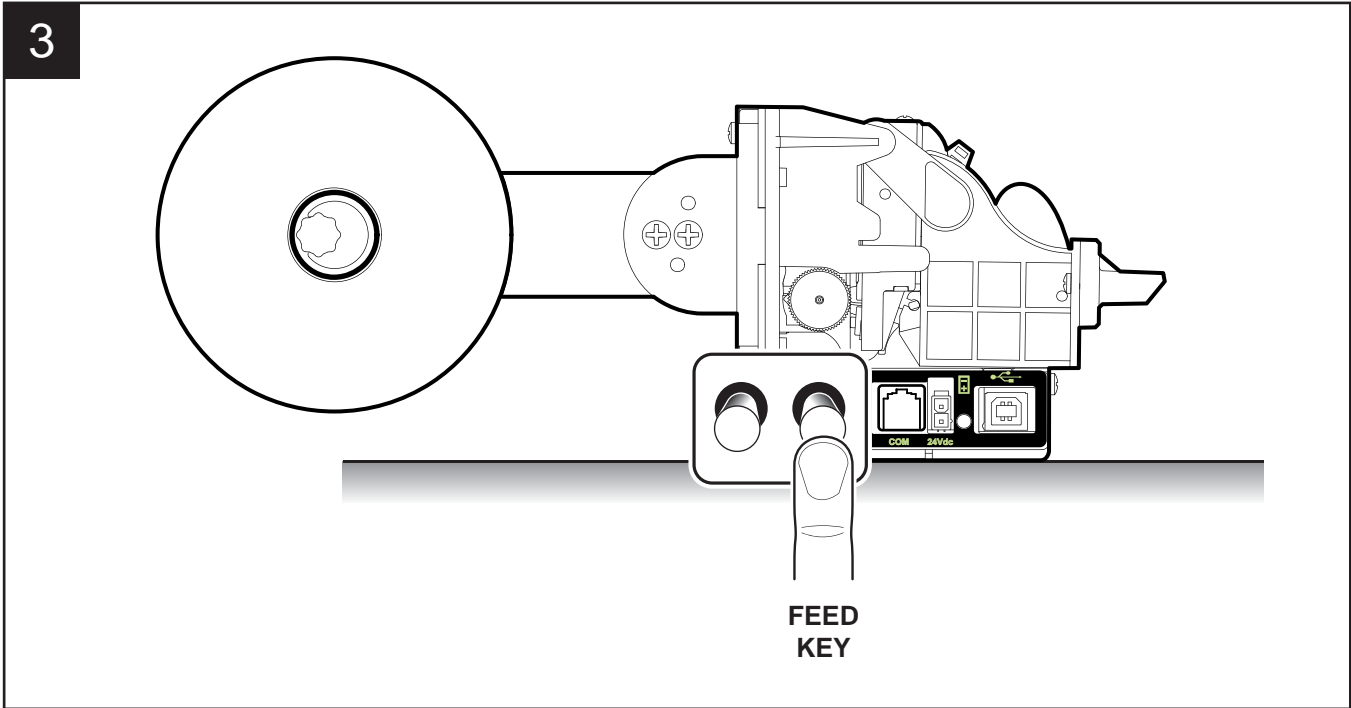

Press the FEED key to enter the configuration mode.

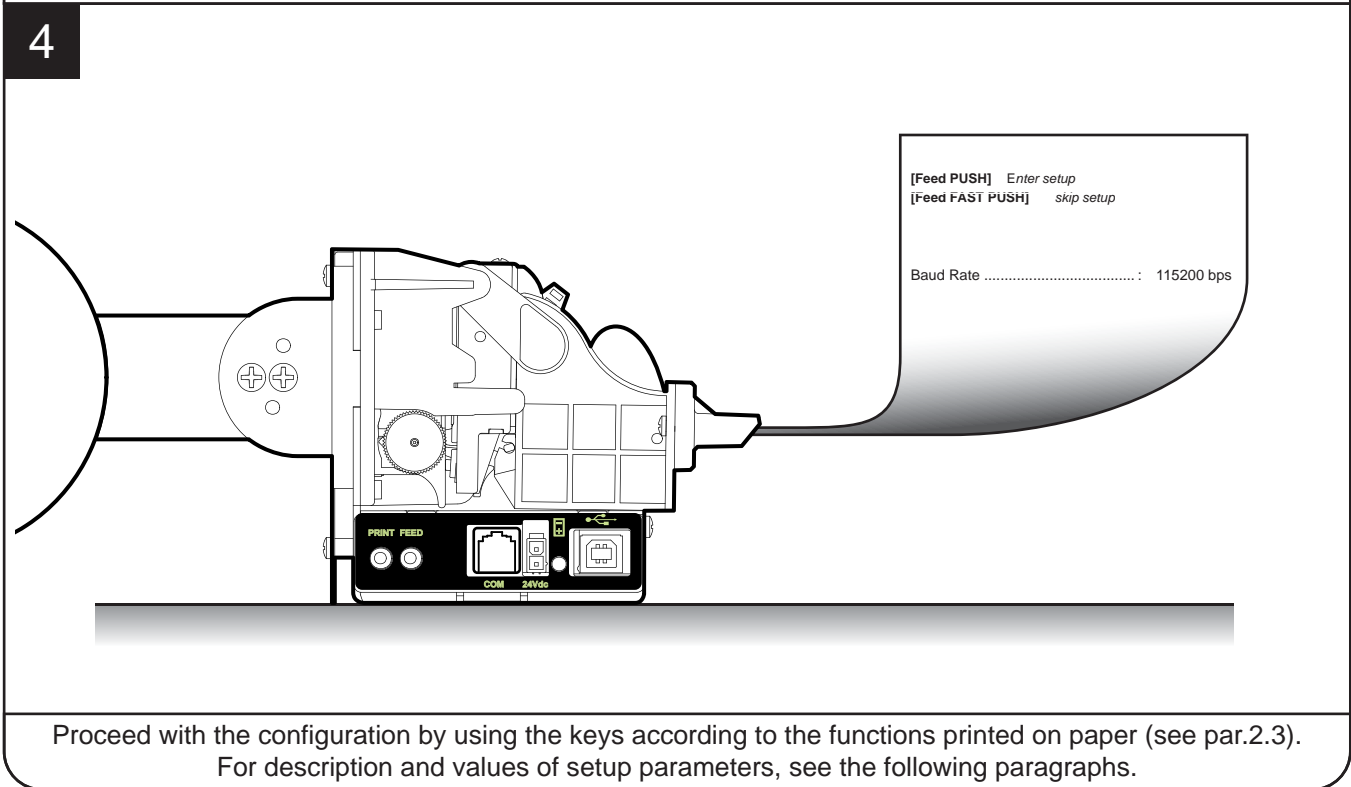

Proceed with the configuration by using the keys according to the functions printed on paper (see par.2.3).  
For description and values of setup parameters, see the following paragraphs.

**NOTE:**

During power-up, if the FEED key is held down, the printer enters the auto-test routine and prints out the setup report. The printer will remain in standby in Hexadecimal dump mode (see following paragraphs) until another key is pressed or characters are received through the printer communication port. When the FEED key is pressed, the printer enters parameter configuration. When the FEED key is pressed shortly, the printer exits setup and terminates the Hexadecimal dump function.

## 5.2 Setup report

The following figure shows the setup report of the printer. The shown values for parameters are sample values; for the list and the description of printer parameters see the following paragraphs.

<b>PRINTER NAME and FIRMWARE RELEASE</b> (see chapter 11)	TG2480-H printer      rel 2.00
<b>PRINTER STATUS</b> (see paragraph 5.3)	<h3 style="text-align: center;">PRINTER SETUP</h3>
<b>PRINTER PARAMETERS</b> (see paragraph 5.4)	<pre> PRINTER TYPE ..... TG2480-H BOOTLOADER ..... rel 2.14 BTL CODE..... &lt;code&gt; FW CODE..... &lt;code&gt; HEAD VOLTAGE [V]           = 23.57 HEAD TEMP. [°C]           = 26 CUT COUNTER                = 1 POWERON COUNTER           = 1 PAPER PRINT [cm]         = 40  Baud Rate ..... 19200 bps Data Length ..... 8 bits/chr Parity ..... None Handshaking ..... XON/XOFF Busy Condition ..... RxFull Autofeed ..... CR Disabled USB Address N ..... 0 Print Mode ..... Normal Code Table ..... PC437 Chars / inch ..... A=11 B=15 cpi Speed / Quality ..... Normal Print Width ..... 76mm Notch Align ..... Enabled Notch Thresh. .... 1.50V Notch Dist.mm ..... 00.0 Print Density ..... 0%           </pre>
<b>KEYS FUNCTIONS</b> (see paragraph 2.3)	<pre> [Feed PUSH]  Enter setup [Feed FAST PUSH]  skip Setup           </pre>

## 5. CONFIGURATION

---

### 5.3 Printer status

Printer operating status is indicated in the configuration print-out in which, next to the name of the components displayed, the following information is given:

---

<b>PRINTER TYPE</b>	<i>is given the device model</i>
<b>BOOT LOADER</b>	<i>is given the boot loader release</i>
<b>BTL CODE</b>	<i>are given the code of the firmware module</i>
<b>FW CODE</b>	<i>are given the code of the firmware module</i>
<b>HEAD VOLTAGE</b>	<i>is given the voltage of the head.</i>
<b>HEAD TEMPERATURE</b>	<i>is given the temperature of the head.</i>
<b>CUT COUNTER</b>	<i>is given the number of cuts made.</i>
<b>POWER ON COUNTER</b>	<i>is given the number of power-ups made</i>
<b>PAPER PRINTED</b>	<i>is given the number of centimetres of paper printed.</i>

---

## 5.4 Printer parameters

This printer allows the configuration of the parameters listed in the following table. The parameters marked with the symbol <sup>D</sup> are the default values. Settings remain active even after the printer has been turned off and they are stored in non-volatile memory.

<b>BAUD RATE</b>	<i>Communication speed of the serial interface:</i>
	230400      38400      4800
	115200      19200 <sup>D</sup> 2400
	57600      9600      1200
	<b>NOTE:</b> Parameter valid only with serial interface.
<b>DATA LENGTH</b>	<i>Number of bit used for characters encoding:</i>
	7 bits/car
	8 bits/car <sup>D</sup>
	<b>NOTE:</b> Parameter valid only with serial interface.
<b>PARITY</b>	<i>Bit for the parity control of the serial interface:</i>
	None <sup>D</sup> = parity bit omitted
	Even = even value for parity bit
	Odd = odd value for parity bit
	<b>NOTE:</b> Parameter valid only with serial interface.
<b>HANDSHAKING</b>	<i>Handshaking:</i>
	XON/XOFF <sup>D</sup> = software handshaking
	Hardware = hardware handshaking (CTS/RTS)
	<b>NOTE:</b> Parameter valid only with serial interface. <b>NOTE:</b> When the receive buffer is full, if handshaking is set to XON/XOFF, the printer sends the XOFF (\$13) on the serial port. When the receive buffer has cleared once again, if handshaking is set to XON/XOFF, the printer sends the XON (\$11) on the serial port.
<b>BUSY CONDITION</b>	<i>Activation mode for Busy signal:</i>
	OffLine/ RXFull = Busy signal is activated when the printer is both in OffLine status and the buffer is full
	RXFull <sup>D</sup> = Busy signal is activated when the buffer is full
	<b>NOTE:</b> Parameter valid only with serial interface.
<b>AUTOFEED</b>	<i>Setting of the Carriage Return character:</i>
	CR disabled <sup>D</sup> = Carriage Return disabled CR enabled = Carriage Return enabled
<b>USB ADDRESS NUMBER</b>	<i>Numerical address code for the univocal identification of the USB device (in case of more than a USB device connected with the same PC):</i>
	0 <sup>D</sup> 4      8
	1      5      9
	2      6
	3      7
<b>PRINT MODE</b>	<i>Printing mode:</i>
	Normal <sup>D</sup> = enables printing in normal writing way
	Reverse = enables printing rotated 180 degrees

## 5. CONFIGURATION

<b>CODE TABLE</b>	<i>Character code table:</i>		
	PC437 <sup>D</sup> U.D.P. PC850 PC860 PC863	PC865 PC858 PC866 VISCII	
<b>NOTE:</b> This parameter is not printed in the version with simplified chinese font GB2312			
<b>CHARS / INCH</b>	<i>Font selection:</i>		
	A = 11 cpi, B = 15 cpi <sup>D</sup> A = 15 cpi, B = 20 cpi		
<b>NOTE:</b> CPI = Characters Per Inch			
<b>SPEED / QUALITY</b>	<i>Setting of printing speed and printing quality:</i>		
	Normal <sup>D</sup> Low		
<b>PRINT WIDTH</b>	<i>Width of printing area:</i>		
	52 mm 56 mm 60 mm 64 mm	68 mm 72 mm 76 mm <sup>D</sup> 80 mm	
<b>NOTCH ALIGNMENT</b>	<i>Management of the alignment notch</i>		
	Disabled <sup>D</sup> = the notch alignment is not performed Enabled = the notch alignment is performed		
<b>NOTCH THRESHOLD</b>	<i>Threshold value for the recognition of the presence of notch by the notch sensor:</i>		
	0,75V 1,00V 1,25V <sup>D</sup>	1,50V 1,75V 2,00V	2,25V 2,50V 2,75V
<b>NOTE:</b> If the "Notch Alignment" parameter is disabled, this parameter is not printed.			
<b>NOTCH DISTANCE</b>	<i>"Notch Distance" is the minimum distance (in mm) between the upper edge of ticket and the notch. The numeric value of the distance is made up with the following three parameters for the setting of three digits (two for the integer part of the number and one for the decimal part):</i>		
		<i>Setting the digit for tens:</i>	
	<b>NOTCH DISTANCE [mm x 10]</b>	0 <sup>D</sup> 1	
		<i>Setting the digit for units:</i>	
	<b>NOTCH DISTANCE [mm x 1]</b>	0 <sup>D</sup> 1 2	

---

*Setting the digit for decimals:*

<b>NOTCH DISTANCE [mm x .1]</b>	0 <sup>D</sup>	4	8
	1	5	9
	2	6	
	3	7	

**NOTE:** For example, to set the notch distance to 10 mm, modify the parameters as follows:

*Notch Distance [mm x 10] = 1*

*Notch Distance [mm x 1] = 0*

*Notch Distance [mm x .1] = 0*

**NOTE:** If the "Notch Alignment" parameter is disabled, the parameters for the "Notch Distance" are not printed.

---

**PRINT DENSITY**

*Adjusting the printing density:*

-50%	-12%	+25%
-37%	0% <sup>D</sup>	+37%
-25%	+12%	+50%

---

### 5.5 Hexadecimal dump

This function is used to diagnose the characters received through the communication port; the characters are printed out both as hexadecimal codes and ASCII codes.

Once the self-test routine has finished, the printer enters Hexadecimal Dump mode. The printer remains in standby until a key is pressed or characters are received through the communication port. For example, for every 8 characters received, the hexadecimal and corresponding ASCII codes are printed out (if the characters are underlined, the receive buffer is full). Shown below is an example of a Hexadecimal Dump:

HEXADECIMAL DUMP	
31 32 33 34 35 36 37 38	<u>12345678</u>
39 30 31 32 33 34 35 36	<u>90123456</u>
37 38 39 75 69 73 64 66	<u>789uisdf</u>
68 6B 6A 73 64 68 66 68	<u>hkjsdhfh</u>
73 64 66 6B 6A 68 73 64	<u>sdfkjhsd</u>
66 73 64 66 6B 68 6A 77	<u>fsdfkhjw</u>
65 69 6F 79 75 77 71 65	<u>eioyuwqe</u>
6F 72 69 75 77 65 72 69	<u>oriuweri</u>
6F 75 77 65 72 69 6F 75	<u>ouweriou</u>
77 65 72 69 6F 75 77 65	<u>weriouwe</u>
72 69 6F 75 77 65 72 68	<u>riouwerh</u>
6B 6C 73 64 66 68 6B 73	<u>klcdfhks</u>
64 66 6B 73 64 66 68 6A	<u>dfksdfhj</u>
73 64 66 6B 6A F2 73 64	<u>sdfkj&gt;sd</u>
66 6B F2 6A 73 68 64 66	<u>fk&gt;jshdf</u>
6A 6B 6C 68	<u>jklh</u>



## 6 MAINTENANCE

### 6.1 Paper jam

In case of paper jam proceed as follow:

1

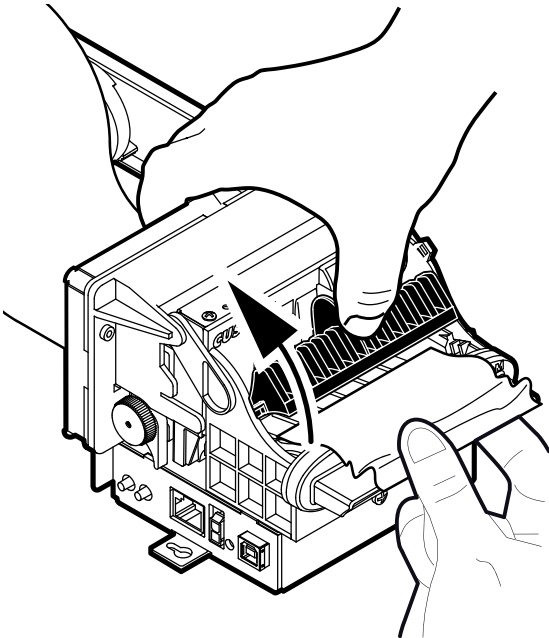

Lift the inspection door and remove possible scraps of paper.

2

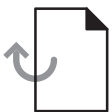

**SEE PREVIOUS  
PARAGRAPHS**

Open the printer.

3

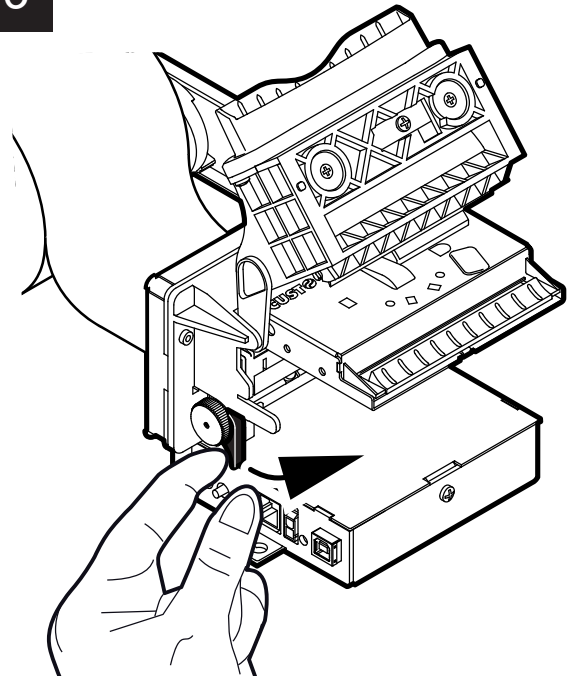

Lift the unblocking lever for rubbed roller.

4

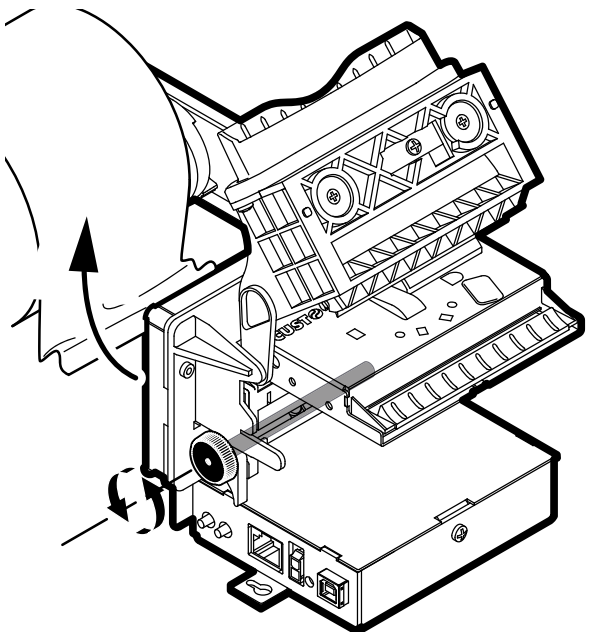

Rotate the rubbed roller clockwise to eject the paper.

## 6. MAINTENANCE

---

### 6.2 Planning of cleaning operations

The regular cleaning of the device keeps the print quality and extends its life. The following table shows the recommended planning for the cleaning operations.

EVERY ROLL CHANGE	
Rollers	Use isopropyl alcohol
EVERY 5 ROLL CHANGES *	
Paper path	Use compressed air or tweezers
EVERY 6 MONTHS OR AS NEEDED *	
Printer case	Use compressed air or a soft cloth

\* If you use the device in dusty environments, you must reduce the intervals between the cleaning operations.

For specific procedures, see the following pages.

6.3 Cleaning

ROLLERS

1

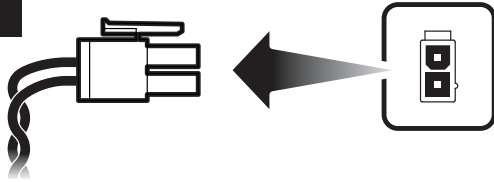

Disconnect the power supply cable.

2

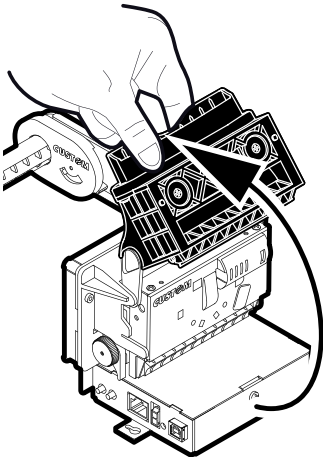

Rotate the paper mouth unit to the maximum opening position

3

**ATTENTION:**  
Do not touch the head heating line with bare hands or metal objects.  
Do not perform any operation inside the printer immediately after printing because the head and motor tend to become very hot.

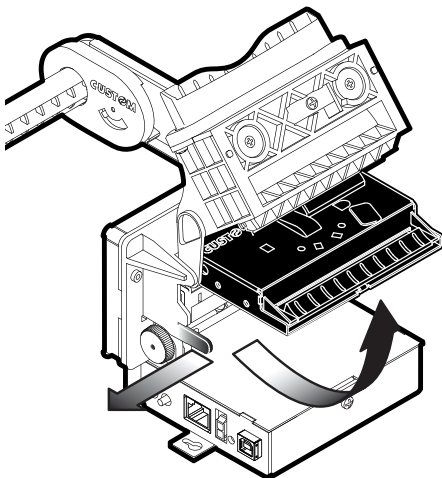

Wide the blocking lever for cutter unit and rotate the cutter unit up

4

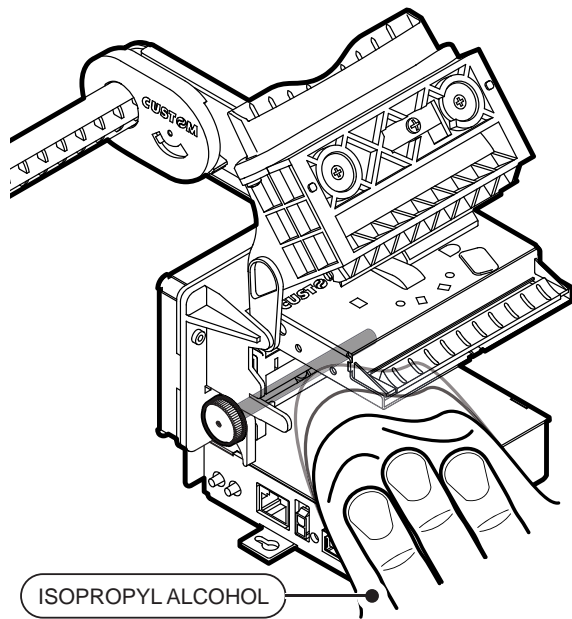

ISOPROPYL ALCOHOL

**ATTENTION:**  
Do not use alcohol, solvents, or hard brushes. Do not let water or other liquids get inside the machine.



Clean the dragging roller by using a soft cloth moistened with isopropyl.

PAPER PATH

1

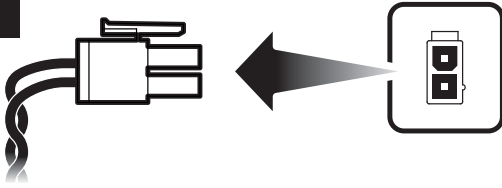

Disconnect the power supply cable.

2

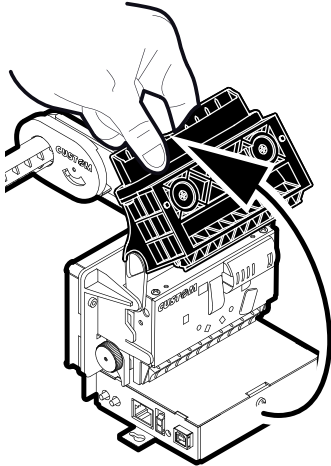

Rotate the paper mouth unit to the maximum opening position

3

**ATTENTION:**  
Do not touch the head heating line with bare hands or metal objects. Do not perform any operation inside the printer immediately after printing because the head and motor tend to become very hot.

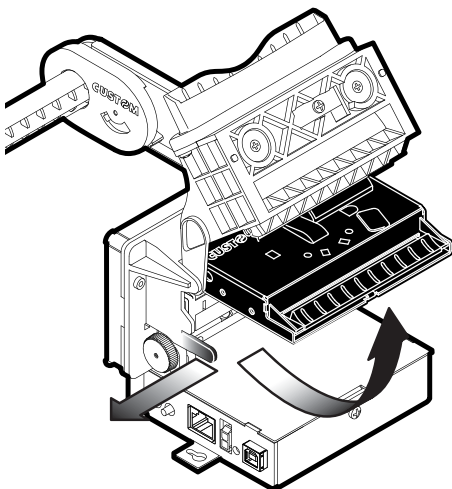

Wide the blocking lever for cutter unit and rotate the cutter unit up

4

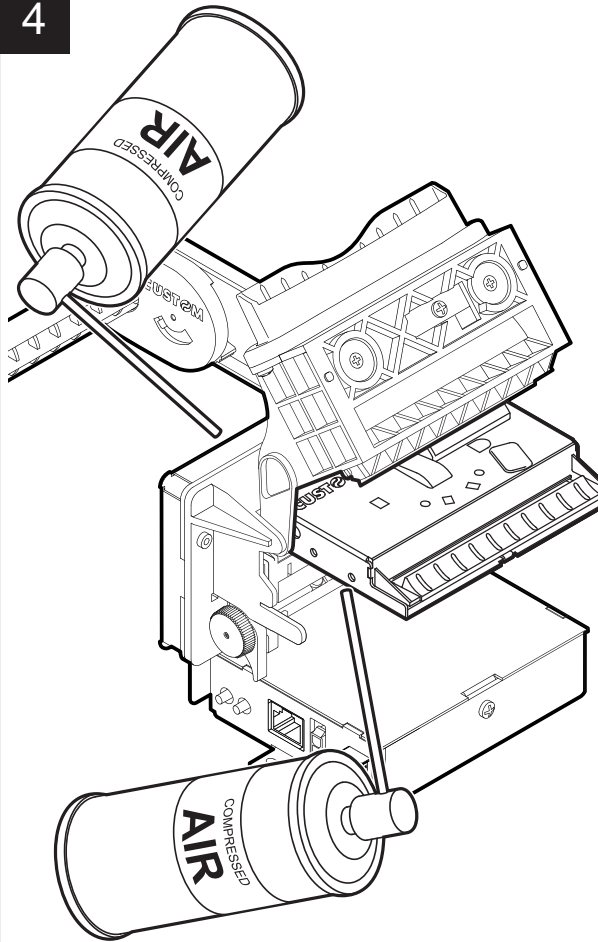

**ATTENTION:**  
Do not use alcohol, solvents, or hard brushes. Do not let water or other liquids get inside the machine. To remove paper scraps, use tweezers or compressed air.

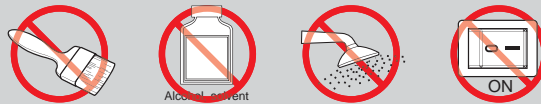

Carefully clean the paper path by using compressed air. Remove any scraps of paper and the accumulated paper dust on the printing roller and on the area around the sensors

## CASE

1

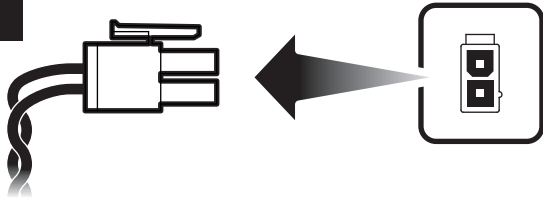

Disconnect the  
power supply cable

2

**ATTENTION:**

Do not use alcohol, solvents, or hard brushes. Do not let water or other liquids get inside the machine.

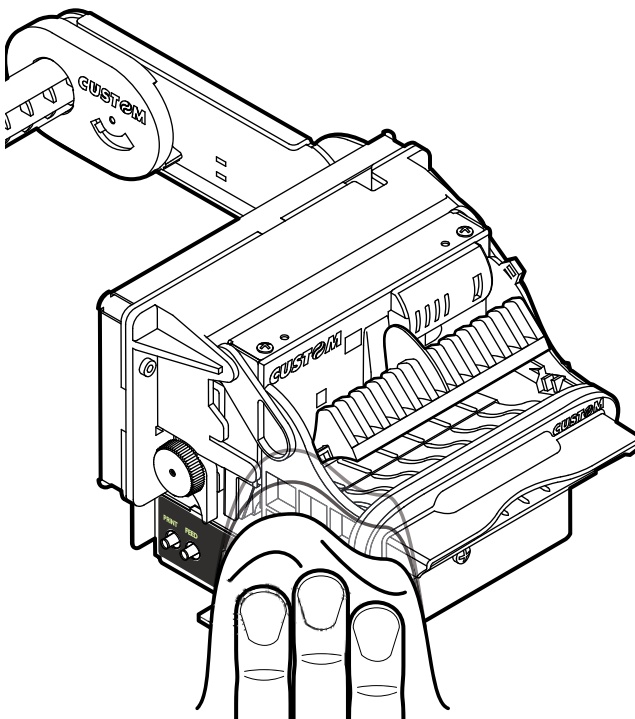

To clean the machine,  
use pneumatic air or soft cloth

### 6.4 Upgrade firmware

**WARNING:** During communication between PC/printer for the firmware update it is strictly forbidden to disconnect the communication cable or to remove the power supply of the devices not to endanger the proper functioning of the printer.

**Note:** The latest firmware of the printer is available in the download area of the web site [www.custom.biz](http://www.custom.biz).

**Note:** Install on the PC used for printer upgrading the UPGCEPRN software available in the download area of the web site [www.custom.biz](http://www.custom.biz).

#### UPDATE VIA SERIAL INTERFACE

Proceed as follows:

1. Print the SETUP report (see chapter 5).
2. Switch OFF the printer.
3. Connect the printer to the PC using a serial cable (see paragraph 3.3).
4. Switch ON the printer.
5. Start the software UPGCEPRN.
6. Select the update file .PSW location :

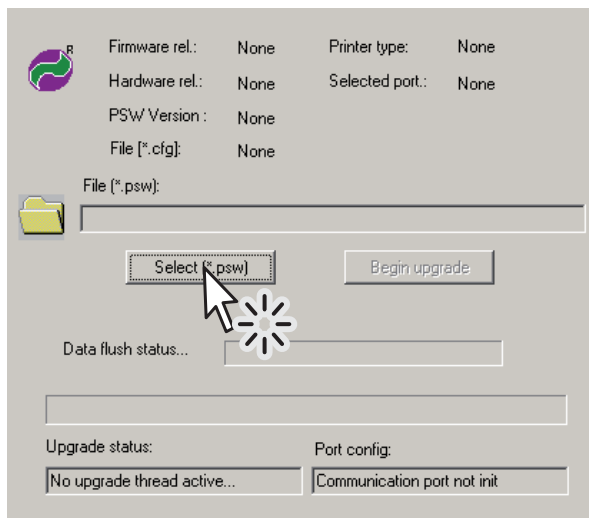

7. Select the serial communication port (ex. COM1):

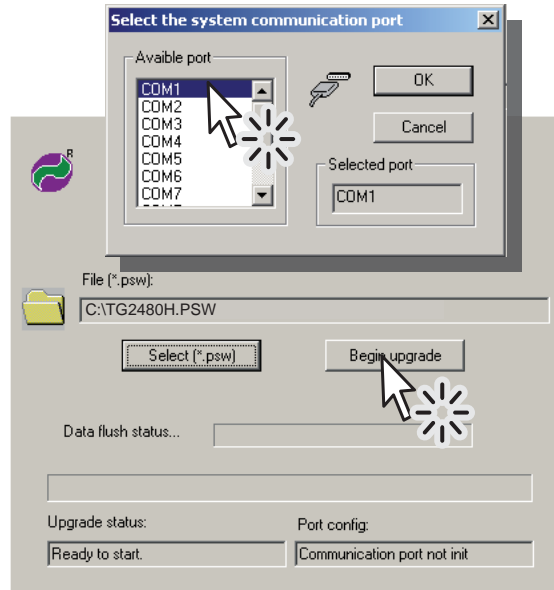

8. Detecting and setting of the parameters necessary for serial communication are performed automatically and then updating begins.
9. After a few minutes a message on the screen warns that the update is completed.

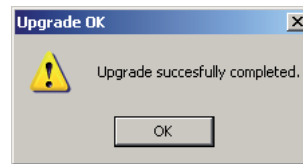

10. Print a new SETUP report to verify the new firmware release (see chapter 5).

#### UPDATE VIA USB INTERFACE

**ATTENTION:** Only during the firmware update, the connection between PC and printer must be direct, without the use of wireless HUB.

**ATTENTION:** Only during the firmware update, do not connect or disconnect other USB devices.

**NOTE:** For communication via USB you must install on PC the printer driver available in the download area of the web site [www.custom.biz](http://www.custom.biz).

Proceed as follows:

1. Print the SETUP report (see chapter 5).
2. Switch OFF the printer.

3. Connect the printer to the PC using a USB cable (see paragraph 3.3).
4. Switch ON the printer.
5. Start the software UPGCEPRN.
6. Select the update file .PSW location:
8. After a few minutes a message on the screen warns that the update is completed.

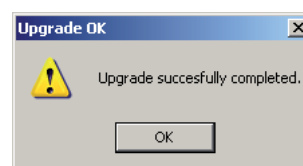
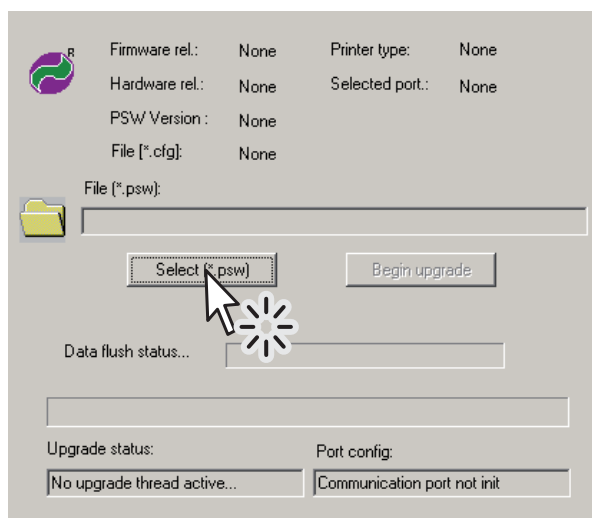

7. Select item USB and then select the USB device among those proposed (ex. TG2480-H):

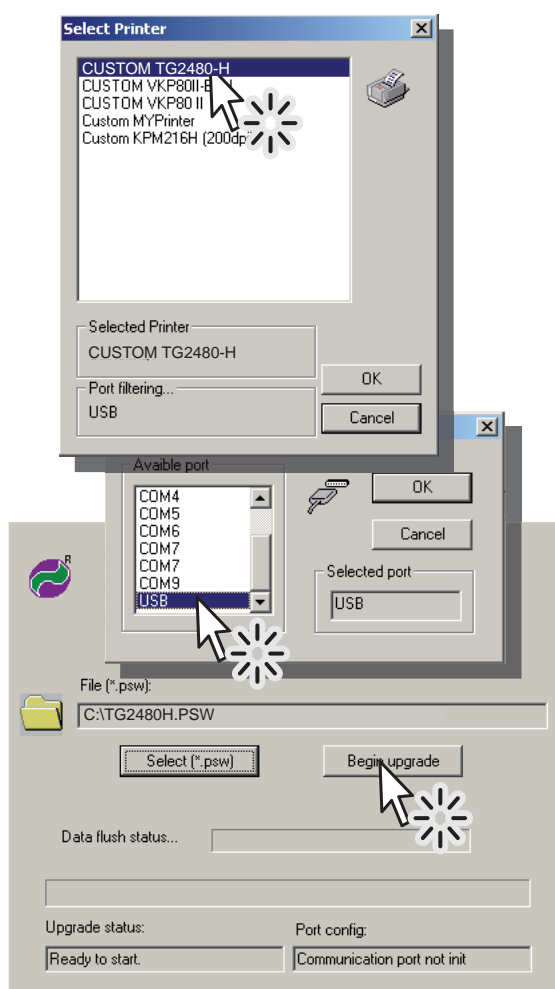





## 7 SPECIFICATIONS

### 7.1 Hardware specifications

GENERAL	
Sensors	Head temperature, paper presence, paper jam, ticket withdrawal, external near paper end
MTBF <sup>(1)</sup>	171 735 hours
Noise level	63 dB
Emulations	ESC/POS™
Drivers	Windows XP, VISTA (32/64bit), Windows 7 (32/64bit), OPOS, Linux
INTERFACES	
RS232 serial connector (RJ45)	from 1200 to 115200 bps
USB connector	USB 1.1= 12 Mbit/sec
MEMORY SPECIFICATIONS	
Flash memory	1 Mbytes
Receive buffer	2 Kbytes
Graphic memory	2 logos (608 x 430 dots)
PRINTER SPECIFICATIONS	
Resolution	203 DPI (8 dot/mm)
Printing method	Thermal, fixed head
Head life <sup>(2)</sup>	50 Km
Print width	(paper 80mm) 76 mm
Printing mode	Straight, 180°
Printing format	Normal, height / width from 1 to 4, bold, reverse, underlined, italic
Character fonts (TG2480H)	PC437, PC850, PC860, PC863, PC865, PC858, PC866, VISCII, U.D.P.
Character fonts <sup>(3)</sup> (TG2480H with chinese fonts)	PC437, PC850, PC860, PC863, PC865, PC858, GB2312
Printable barcode	UPCA, UPCE, EAN13, EAN8, CODE39, ITF, CODABAR, CODE93, CODE128, CODE32
Printing speed <sup>(2) (4)</sup>	Normal = 100 mm/sec High speed = 130 mm/sec
PAPER SPECIFICATIONS	
Type of paper	Thermal rolls Heat-sensitive side on outside of roll
Paper roll size	80 mm ± 0,5
Paper weight	from 55 g/m <sup>2</sup> to 80 g/m <sup>2</sup>
Recommended types of paper	KANZAN KF50 or KP460, MITSUBISHI PG5075 or TL4000
Paper thickness	63 µm ± 0,5 µm (for 55 g/m <sup>2</sup> paper type) 85 µm ± 0,6 µm (for 80 g/m <sup>2</sup> paper type)
Paper end	Not attached to roll core
External roll diameter	max Ø 90 mm

## 7. SPECIFICATIONS

Internal roll core diameter	25 mm
Core type	Cardboard or plastic
Minimum ticket length	110 mm
<b>CUTTER SPECIFICATIONS</b>	
Cutting method	Total
Cutter reliability	1 000 000 cuts
<b>ELECTRICAL SPECIFICATIONS TG2480H</b>	
Power supply	24 Vdc $\pm$ 10% (alimentatore esterno opzionale)
Average <sup>(3)</sup>	0,8 A
Stand-by	0,05 A
<b>ELECTRICAL SPECIFICATIONS POWER SUPPLY cod.964GE010000362 (OPTIONAL)</b>	
Power supply voltage	from 88Vac to 264Vac
Frequency	from 47Hz to 63Hz
Current (output)	4,5 A
Power	100 W
<b>ENVIRONMENTAL CONDITIONS</b>	
Operating temperature	from 0°C to + 50°C
Relative humidity	from 10% Rh to 85% Rh
Storage temperature	from -20 °C to +70 °C
Storage relative humidity	from 10% Rh to 90% Rh

### NOTES:

<sup>(1)</sup> : Control board

<sup>(2)</sup> : Respecting the regular schedule of cleaning for the device components.

<sup>(3)</sup> : For further information refer to the command manual for managing chinese fonts.

<sup>(4)</sup> : Referred to a standard CUSTOM receipt (L = 10cm, Density = 12,5% dots on).

## 7.2 Character specifications

ESC/POS™ EMULATION			
Character set		3	
Character density	11 cpi	15 cpi	20 cpi
Number of columns	33	43	60
Chars / sec	990	1290	1800
Lines / sec	30	30	30
Characters (L x H mm)-Normal	2,2 x 3	1,7 x 3	1,2 x 3

**NOTE:**

Referred to the default paper width (76mm).

## 7.3 Printer dimensions

Length	165,5 mm <i>(with paper holder support in vertical position)</i> 271,5 mm <i>(with paper holder support in horizontal position)</i> 201,5 mm <i>(with paper holder support in lower position)</i>
Height	191,5 mm <i>(with paper holder support in vertical position)</i> 102 mm <i>(with paper holder support in horizontal position)</i> 156,1 mm <i>(with paper holder support in lower position)</i>
Width	130 mm
Weight	1130 g

**NOTE:**

Referred to model without paper roll.

## 7. SPECIFICATIONS

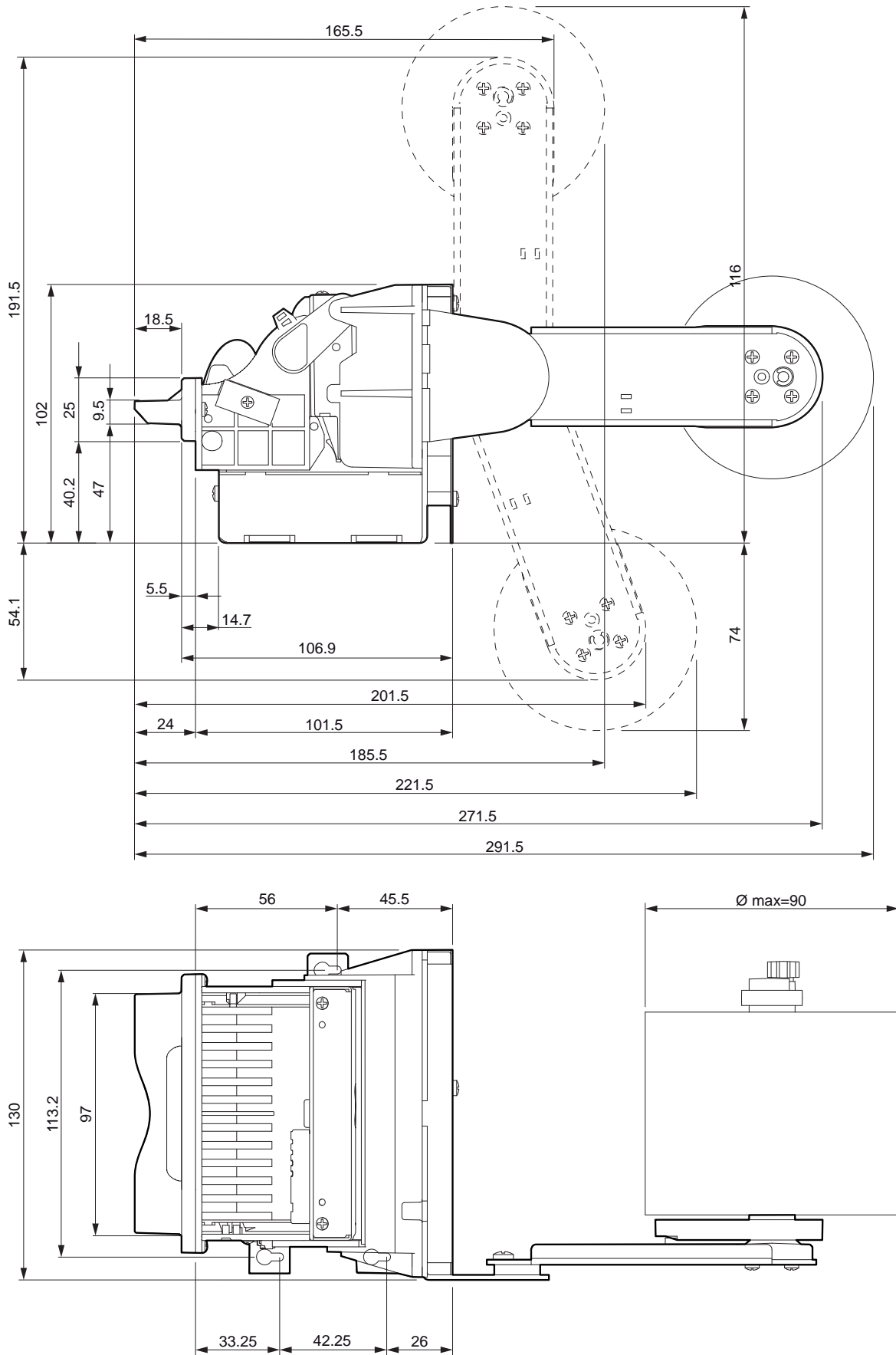

7.4 Power supply dimensions cod. 964GE010000362 (optional)

Length	159 mm
Height	38 mm
Width	95 mm

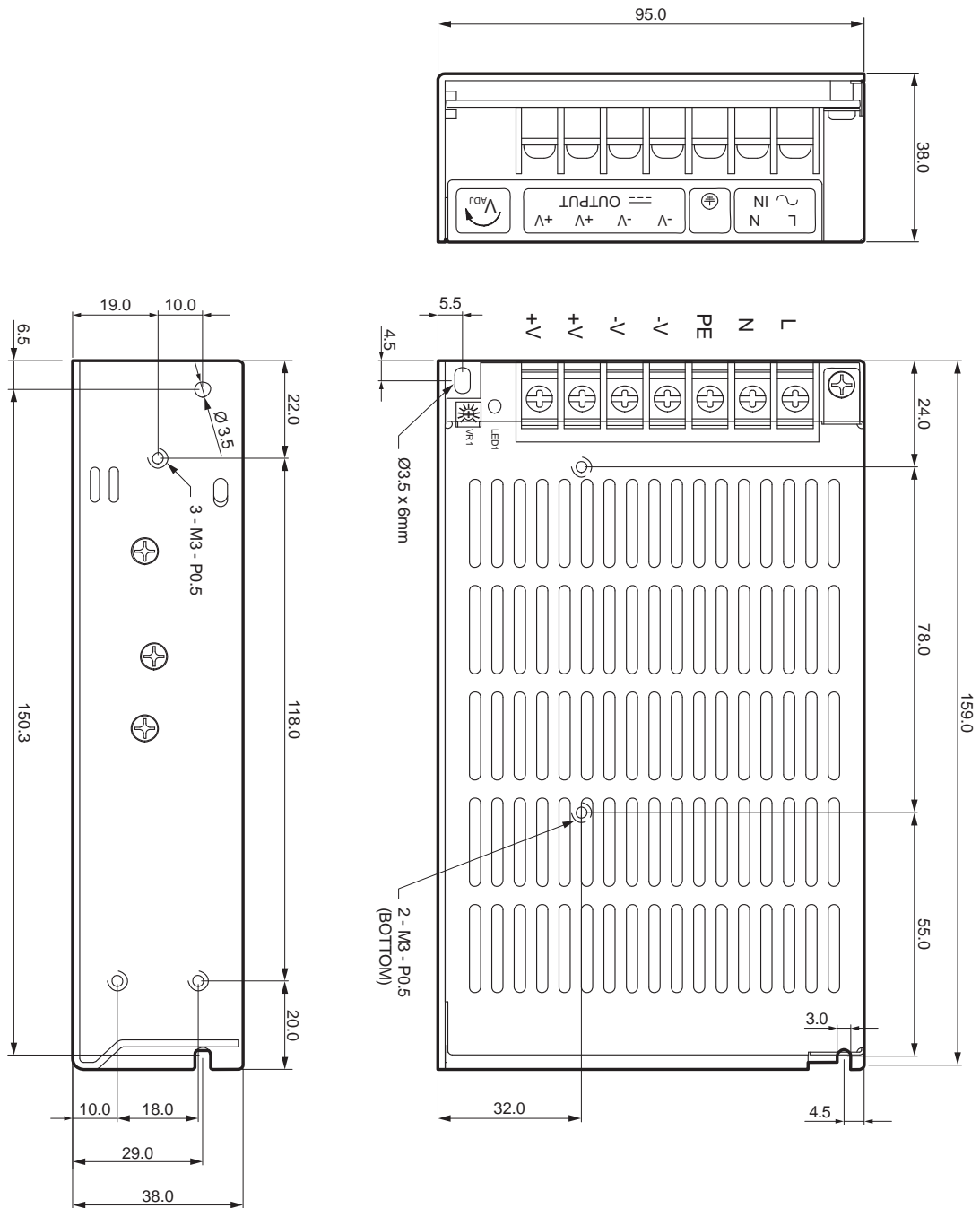

## 7. SPECIFICATIONS

### 7.5 Paper specifications with notch alignment

The following figure shows a sample paper with alignment notch placed on the non-heat sensitive side of paper.

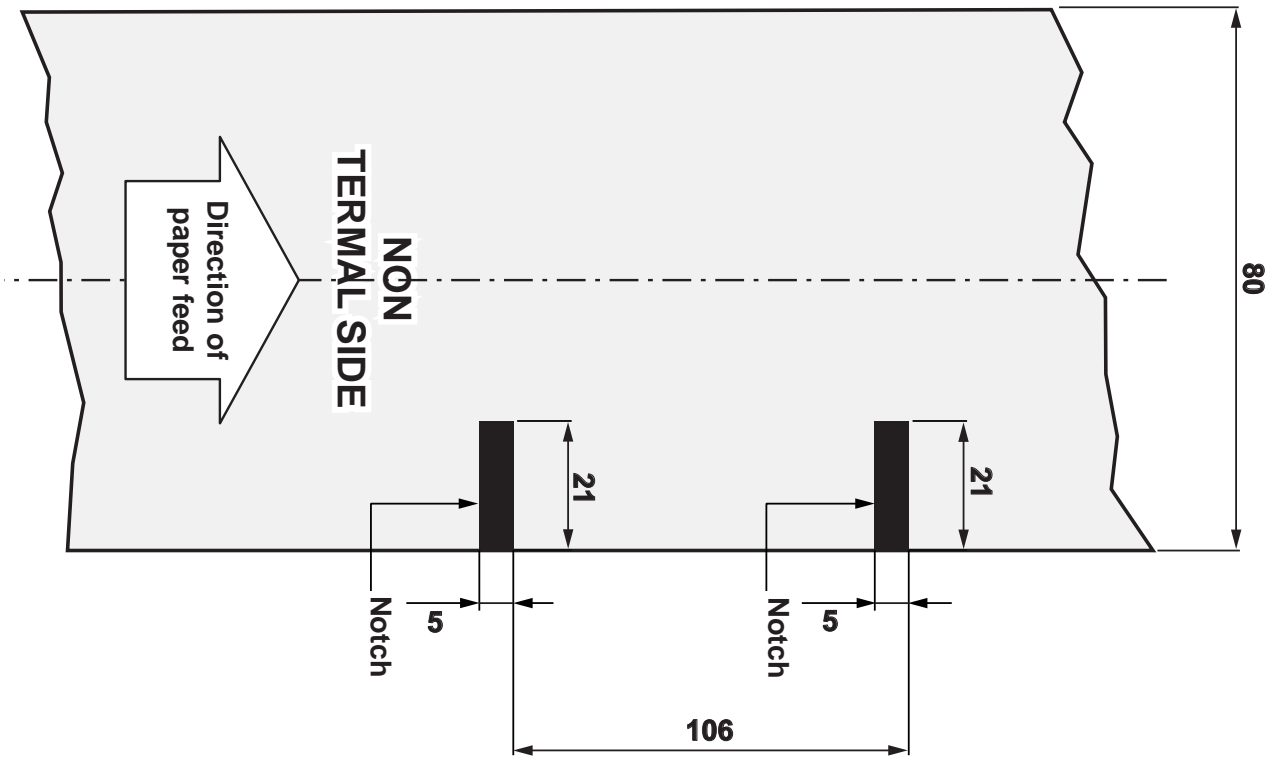

### 7.6 Standard character sets

The printer has 3 fonts of varying width (11, 15 and 20 cpi) which may be accessed through programming or control characters.







Each of these fonts offers the following code tables: PC437, PC850, PC860, PC863, PC865, PC858, PC866, VISCII

**PC437 CODE TABLE (Usa, Standard Europe)**

Char	<b>SP</b>	<b>!</b>	<b>“</b>	<b>#</b>	<b>\$</b>	<b>%</b>	<b>&amp;</b>	<b>‘</b>	<b>(</b>	<b>)</b>	<b>*</b>	<b>+</b>	<b>,</b>	<b>-</b>	<b>.</b>	<b>/</b>
Hex	0020	0021	0022	0023	0024	0025	0026	0027	0028	0029	002A	002B	002C	002D	002E	002F
Dec	32	33	34	35	36	37	38	39	40	41	42	43	44	45	46	47
Char	<b>0</b>	<b>1</b>	<b>2</b>	<b>3</b>	<b>4</b>	<b>5</b>	<b>6</b>	<b>7</b>	<b>8</b>	<b>9</b>	<b>:</b>	<b>;</b>	<b>&lt;</b>	<b>=</b>	<b>&gt;</b>	<b>?</b>
Hex	0030	0031	0032	0033	0034	0035	0036	0037	0038	0039	003A	003B	003C	003D	003E	003F
Dec	48	49	50	51	52	53	54	55	56	57	58	59	60	61	62	63
Char	<b>@</b>	<b>A</b>	<b>B</b>	<b>C</b>	<b>D</b>	<b>E</b>	<b>F</b>	<b>G</b>	<b>H</b>	<b>I</b>	<b>J</b>	<b>K</b>	<b>L</b>	<b>M</b>	<b>N</b>	<b>O</b>
Hex	0040	0041	0042	0043	0044	0045	0046	0047	0048	0049	004A	004B	004C	004D	004E	004F
Dec	64	65	66	67	68	69	70	71	72	73	74	75	76	77	78	79
Char	<b>P</b>	<b>Q</b>	<b>R</b>	<b>S</b>	<b>T</b>	<b>U</b>	<b>V</b>	<b>W</b>	<b>X</b>	<b>Y</b>	<b>Z</b>	<b>[</b>	<b>\</b>	<b>]</b>	<b>^</b>	<b>_</b>
Hex	0050	0051	0052	0053	0054	0055	0056	0057	0058	0059	005A	005B	005C	005D	005E	005F
Dec	80	81	82	83	84	85	86	87	88	89	90	91	92	93	94	95
Char	<b>`</b>	<b>a</b>	<b>b</b>	<b>c</b>	<b>d</b>	<b>e</b>	<b>f</b>	<b>g</b>	<b>h</b>	<b>i</b>	<b>j</b>	<b>k</b>	<b>l</b>	<b>m</b>	<b>n</b>	<b>o</b>
Hex	0060	0061	0062	0063	0064	0065	0066	0067	0068	0069	006A	006B	006C	006D	006E	006F
Dec	96	97	98	99	100	101	102	103	104	105	106	107	108	109	110	111
Char	<b>p</b>	<b>q</b>	<b>r</b>	<b>s</b>	<b>t</b>	<b>u</b>	<b>v</b>	<b>w</b>	<b>x</b>	<b>y</b>	<b>z</b>	<b>{</b>	<b> </b>	<b>}</b>	<b>~</b>	<b>␣</b>
Hex	0070	0071	0072	0073	0074	0075	0076	0077	0078	0079	007A	007B	007C	007D	007E	007F
Dec	112	113	114	115	116	117	118	119	120	121	122	123	124	125	126	127
Char	<b>Ç</b>	<b>ü</b>	<b>é</b>	<b>â</b>	<b>ä</b>	<b>à</b>	<b>å</b>	<b>ç</b>	<b>ê</b>	<b>ë</b>	<b>è</b>	<b>ï</b>	<b>î</b>	<b>ì</b>	<b>Ä</b>	<b>Å</b>
Hex	0080	0081	0082	0083	0084	0085	0086	0087	0088	0089	008A	008B	008C	008D	008E	008F
Dec	128	129	130	131	132	133	134	135	136	137	138	139	140	141	142	143
Char	<b>É</b>	<b>æ</b>	<b>Æ</b>	<b>ô</b>	<b>ö</b>	<b>ò</b>	<b>û</b>	<b>ù</b>	<b>ÿ</b>	<b>Ö</b>	<b>Ü</b>	<b>¢</b>	<b>£</b>	<b>¥</b>	<b>Pts</b>	<b>f</b>
Hex	0090	0091	0092	0093	0094	0095	0096	0097	0098	0099	009A	009B	009C	009D	009E	009F
Dec	144	145	146	147	148	149	150	151	152	153	154	155	156	157	158	159
Char	<b>á</b>	<b>í</b>	<b>ó</b>	<b>ú</b>	<b>ñ</b>	<b>Ñ</b>	<b>a</b>	<b>o</b>	<b>¿</b>	<b>¡</b>	<b>½</b>	<b>¼</b>	<b>i</b>	<b>«</b>	<b>»</b>	
Hex	00A0	00A1	00A2	00A3	00A4	00A5	00A6	00A7	00A8	00A9	00AA	00AB	00AC	00AD	00AE	00AF
Dec	160	161	162	163	164	165	166	167	168	169	170	171	172	173	174	175
Char				<b> </b>	<b>†</b>	<b>‡</b>	<b>§</b>	<b>¶</b>	<b>¶</b>	<b>¶</b>	<b>¶</b>	<b>¶</b>	<b>¶</b>	<b>¶</b>	<b>¶</b>	<b>¶</b>
Hex	00B0	00B1	00B2	00B3	00B4	00B5	00B6	00B7	00B8	00B9	00BA	00BB	00BC	00BD	00BE	00BF
Dec	176	177	178	179	180	181	182	183	184	185	186	187	188	189	190	191
Char	<b>L</b>	<b>⊥</b>	<b>T</b>	<b>†</b>	<b>—</b>	<b>†</b>	<b>‡</b>	<b>¶</b>	<b>¶</b>	<b>¶</b>	<b>¶</b>	<b>¶</b>	<b>¶</b>	<b>¶</b>	<b>¶</b>	<b>¶</b>
Hex	00C0	00C1	00C2	00C3	00C4	00C5	00C6	00C7	00C8	00C9	00CA	00CB	00CC	00CD	00CE	00CF
Dec	192	193	194	195	196	197	198	199	200	201	202	203	204	205	206	207
Char	<b>¶</b>	<b>¶</b>	<b>¶</b>	<b>¶</b>	<b>¶</b>	<b>¶</b>	<b>¶</b>	<b>¶</b>	<b>¶</b>	<b>¶</b>	<b>¶</b>	<b>¶</b>	<b>¶</b>	<b>¶</b>	<b>¶</b>	<b>¶</b>
Hex	00D0	00D1	00D2	00D3	00D4	00D5	00D6	00D7	00D8	00D9	00DA	00DB	00DC	00DD	00DE	00DF
Dec	208	209	210	211	212	213	214	215	216	217	218	219	220	221	222	223
Char	<b>α</b>	<b>β</b>	<b>Γ</b>	<b>π</b>	<b>Σ</b>	<b>σ</b>	<b>μ</b>	<b>τ</b>	<b>Φ</b>	<b>Θ</b>	<b>Ω</b>	<b>δ</b>	<b>∞</b>	<b>φ</b>	<b>ε</b>	<b>∩</b>
Hex	00E0	00E1	00E2	00E3	00E4	00E5	00E6	00E7	00E8	00E9	00EA	00EB	00EC	00ED	00EE	00EF
Dec	224	225	226	227	228	229	230	231	232	233	234	235	236	237	238	239
Char	<b>≡</b>	<b>±</b>	<b>≥</b>	<b>≤</b>	<b>∫</b>	<b>∫</b>	<b>÷</b>	<b>≈</b>	<b>°</b>	<b>·</b>	<b>·</b>	<b>√</b>	<b>n</b>	<b>²</b>	<b>■</b>	<b>NBSP</b>
Hex	00F0	00F1	00F2	00F3	00F4	00F5	00F6	00F7	00F8	00F9	00FA	00FB	00FC	00FD	00FE	00FF
Dec	240	241	242	243	244	245	246	247	248	249	250	251	252	253	254	255

















































## 7. SPECIFICATIONS

PC850 CODE TABLE (Multilingual)

Char	<b>SP</b>	<b>!</b>	<b>“</b>	<b>#</b>	<b>\$</b>	<b>%</b>	<b>&amp;</b>	<b>‘</b>	<b>(</b>	<b>)</b>	<b>*</b>	<b>+</b>	<b>,</b>	<b>-</b>	<b>.</b>	<b>/</b>	
Hex	0020	0021	0022	0023	0024	0025	0026	0027	0028	0029	002A	002B	002C	002D	002E	002F	
Dec	32	33	34	35	36	37	38	39	40	41	42	43	44	45	46	47	
Char	<b>0</b>	<b>1</b>	<b>2</b>	<b>3</b>	<b>4</b>	<b>5</b>	<b>6</b>	<b>7</b>	<b>8</b>	<b>9</b>	<b>:</b>	<b>;</b>	<b>&lt;</b>	<b>=</b>	<b>&gt;</b>	<b>?</b>	
Hex	0030	0031	0032	0033	0034	0035	0036	0037	0038	0039	003A	003B	003C	003D	003E	003F	
Dec	48	49	50	51	52	53	54	55	56	57	58	59	60	61	62	63	
Char	<b>@</b>	<b>A</b>	<b>B</b>	<b>C</b>	<b>D</b>	<b>E</b>	<b>F</b>	<b>G</b>	<b>H</b>	<b>I</b>	<b>J</b>	<b>K</b>	<b>L</b>	<b>M</b>	<b>N</b>	<b>O</b>	
Hex	0040	0041	0042	0043	0044	0045	0046	0047	0048	0049	004A	004B	004C	004D	004E	004F	
Dec	64	65	66	67	68	69	70	71	72	73	74	75	76	77	78	79	
Char	<b>P</b>	<b>Q</b>	<b>R</b>	<b>S</b>	<b>T</b>	<b>U</b>	<b>V</b>	<b>W</b>	<b>X</b>	<b>Y</b>	<b>Z</b>	<b>[</b>	<b>\</b>	<b>]</b>	<b>^</b>	<b>_</b>	
Hex	0050	0051	0052	0053	0054	0055	0056	0057	0058	0059	005A	005B	005C	005D	005E	005F	
Dec	80	81	82	83	84	85	86	87	88	89	90	91	92	93	94	95	
Char	<b>`</b>	<b>a</b>	<b>b</b>	<b>c</b>	<b>d</b>	<b>e</b>	<b>f</b>	<b>g</b>	<b>h</b>	<b>i</b>	<b>j</b>	<b>k</b>	<b>l</b>	<b>m</b>	<b>n</b>	<b>o</b>	
Hex	0060	0061	0062	0063	0064	0065	0066	0067	0068	0069	006A	006B	006C	006D	006E	006F	
Dec	96	97	98	99	100	101	102	103	104	105	106	107	108	109	110	111	
Char	<b>p</b>	<b>q</b>	<b>r</b>	<b>s</b>	<b>t</b>	<b>u</b>	<b>v</b>	<b>w</b>	<b>x</b>	<b>y</b>	<b>z</b>	<b>{</b>	<b> </b>	<b>}</b>	<b>~</b>	<b>△</b>	
Hex	0070	0071	0072	0073	0074	0075	0076	0077	0078	0079	007A	007B	007C	007D	007E	007F	
Dec	112	113	114	115	116	117	118	119	120	121	122	123	124	125	126	127	
Char	<b>Ç</b>	<b>ü</b>	<b>é</b>	<b>â</b>	<b>ä</b>	<b>à</b>	<b>á</b>	<b>ç</b>	<b>ê</b>	<b>ë</b>	<b>è</b>	<b>ï</b>	<b>î</b>	<b>ì</b>	<b>Ä</b>	<b>Å</b>	
Hex	0080	0081	0082	0083	0084	0085	0086	0087	0088	0089	008A	008B	008C	008D	008E	008F	
Dec	128	129	130	131	132	133	134	135	136	137	138	139	140	141	142	143	
Char	<b>É</b>	<b>æ</b>	<b>Æ</b>	<b>ô</b>	<b>ö</b>	<b>ò</b>	<b>û</b>	<b>ù</b>	<b>ÿ</b>	<b>Ö</b>	<b>Ü</b>	<b>ø</b>	<b>£</b>	<b>Ø</b>	<b>×</b>	<b>f</b>	
Hex	0090	0091	0092	0093	0094	0095	0096	0097	0098	0099	009A	009B	009C	009D	009E	009F	
Dec	144	145	146	147	148	149	150	151	152	153	154	155	156	157	158	159	
Char	<b>á</b>	<b>í</b>	<b>ó</b>	<b>ú</b>	<b>ñ</b>	<b>Ñ</b>	<b>ª</b>	<b>º</b>	<b>¿</b>	<b>®</b>	<b>¬</b>	<b>½</b>	<b>¼</b>	<b>¡</b>	<b>«</b>	<b>»</b>	
Hex	00A0	00A1	00A2	00A3	00A4	00A5	00A6	00A7	00A8	00A9	00AA	00AB	00AC	00AD	00AE	00AF	
Dec	160	161	162	163	164	165	166	167	168	169	170	171	172	173	174	175	
Char				<b> </b>	<b>†</b>	<b>Á</b>	<b>Â</b>	<b>À</b>	<b>©</b>	<b>‡</b>	<b>¶</b>	<b>¶</b>	<b>¶</b>	<b>¶</b>	<b>¢</b>	<b>¥</b>	<b>¬</b>
Hex	00B0	00B1	00B2	00B3	00B4	00B5	00B6	00B7	00B8	00B9	00BA	00BB	00BC	00BD	00BE	00BF	
Dec	176	177	178	179	180	181	182	183	184	185	186	187	188	189	190	191	
Char	<b>L</b>	<b>⊥</b>	<b>T</b>	<b>†</b>	<b>—</b>	<b>†</b>	<b>ã</b>	<b>Ã</b>	<b>ℓ</b>	<b>ℓ</b>	<b>ℓ</b>	<b>ℓ</b>	<b>ℓ</b>	<b>=</b>	<b>¶</b>	<b>¤</b>	
Hex	00C0	00C1	00C2	00C3	00C4	00C5	00C6	00C7	00C8	00C9	00CA	00CB	00CC	00CD	00CE	00CF	
Dec	192	193	194	195	196	197	198	199	200	201	202	203	204	205	206	207	
Char	<b>ø</b>	<b>Ð</b>	<b>Ê</b>	<b>Ë</b>	<b>È</b>	<b>ı</b>	<b>í</b>	<b>î</b>	<b>ï</b>	<b>Ƶ</b>	<b>ƶ</b>			<b>ı</b>	<b>ı</b>		
Hex	00D0	00D1	00D2	00D3	00D4	00D5	00D6	00D7	00D8	00D9	00DA	00DB	00DC	00DD	00DE	00DF	
Dec	208	209	210	211	212	213	214	215	216	217	218	219	220	221	222	223	
Char	<b>Ó</b>	<b>ß</b>	<b>Ô</b>	<b>Ò</b>	<b>õ</b>	<b>Õ</b>	<b>µ</b>	<b>þ</b>	<b>Þ</b>	<b>Ú</b>	<b>Û</b>	<b>Ù</b>	<b>ý</b>	<b>Ý</b>	<b>—</b>	<b>´</b>	
Hex	00E0	00E1	00E2	00E3	00E4	00E5	00E6	00E7	00E8	00E9	00EA	00EB	00EC	00ED	00EE	00EF	
Dec	224	225	226	227	228	229	230	231	232	233	234	235	236	237	238	239	
Char	<b>SHY</b>	<b>±</b>	<b>=</b>	<b>¾</b>	<b>¶</b>	<b>§</b>	<b>÷</b>	<b>˘</b>	<b>◦</b>	<b>˙</b>	<b>.</b>	<b>1</b>	<b>3</b>	<b>2</b>		<b>NBSP</b>	
Hex	00F0	00F1	00F2	00F3	00F4	00F5	00F6	00F7	00F8	00F9	00FA	00FB	00FC	00FD	00FE	00FF	
Dec	240	241	242	243	244	245	246	247	248	249	250	251	252	253	254	255	



PC860 CODE TABLE (Portuguese)



















































Char	<b>SP</b>	<b>!</b>	<b>“</b>	<b>#</b>	<b>\$</b>	<b>%</b>	<b>&amp;</b>	<b>‘</b>	<b>(</b>	<b>)</b>	<b>*</b>	<b>+</b>	<b>,</b>	<b>-</b>	<b>.</b>	<b>/</b>
Hex	0020	0021	0022	0023	0024	0025	0026	0027	0028	0029	002A	002B	002C	002D	002E	002F
Dec	32	33	34	35	36	37	38	39	40	41	42	43	44	45	46	47
Char	<b>0</b>	<b>1</b>	<b>2</b>	<b>3</b>	<b>4</b>	<b>5</b>	<b>6</b>	<b>7</b>	<b>8</b>	<b>9</b>	<b>:</b>	<b>;</b>	<b>&lt;</b>	<b>=</b>	<b>&gt;</b>	<b>?</b>
Hex	0030	0031	0032	0033	0034	0035	0036	0037	0038	0039	003A	003B	003C	003D	003E	003F
Dec	48	49	50	51	52	53	54	55	56	57	58	59	60	61	62	63
Char	<b>@</b>	<b>A</b>	<b>B</b>	<b>C</b>	<b>D</b>	<b>E</b>	<b>F</b>	<b>G</b>	<b>H</b>	<b>I</b>	<b>J</b>	<b>K</b>	<b>L</b>	<b>M</b>	<b>N</b>	<b>O</b>
Hex	0040	0041	0042	0043	0044	0045	0046	0047	0048	0049	004A	004B	004C	004D	004E	004F
Dec	64	65	66	67	68	69	70	71	72	73	74	75	76	77	78	79
Char	<b>P</b>	<b>Q</b>	<b>R</b>	<b>S</b>	<b>T</b>	<b>U</b>	<b>V</b>	<b>W</b>	<b>X</b>	<b>Y</b>	<b>Z</b>	<b>[</b>	<b>\</b>	<b>]</b>	<b>^</b>	<b>_</b>
Hex	0050	0051	0052	0053	0054	0055	0056	0057	0058	0059	005A	005B	005C	005D	005E	005F
Dec	80	81	82	83	84	85	86	87	88	89	90	91	92	93	94	95
Char	<b>`</b>	<b>a</b>	<b>b</b>	<b>c</b>	<b>d</b>	<b>e</b>	<b>f</b>	<b>g</b>	<b>h</b>	<b>i</b>	<b>j</b>	<b>k</b>	<b>l</b>	<b>m</b>	<b>n</b>	<b>o</b>
Hex	0060	0061	0062	0063	0064	0065	0066	0067	0068	0069	006A	006B	006C	006D	006E	006F
Dec	96	97	98	99	100	101	102	103	104	105	106	107	108	109	110	111
Char	<b>p</b>	<b>q</b>	<b>r</b>	<b>s</b>	<b>t</b>	<b>u</b>	<b>v</b>	<b>w</b>	<b>x</b>	<b>y</b>	<b>z</b>	<b>{</b>	<b> </b>	<b>}</b>	<b>~</b>	<b>␣</b>
Hex	0070	0071	0072	0073	0074	0075	0076	0077	0078	0079	007A	007B	007C	007D	007E	007F
Dec	112	113	114	115	116	117	118	119	120	121	122	123	124	125	126	127
Char	<b>Ç</b>	<b>ü</b>	<b>é</b>	<b>â</b>	<b>ã</b>	<b>à</b>	<b>Á</b>	<b>ç</b>	<b>ê</b>	<b>Ê</b>	<b>è</b>	<b>í</b>	<b>Ô</b>	<b>ì</b>	<b>Ã</b>	<b>Â</b>
Hex	0080	0081	0082	0083	0084	0085	0086	0087	0088	0089	008A	008B	008C	008D	008E	008F
Dec	128	129	130	131	132	133	134	135	136	137	138	139	140	141	142	143
Char	<b>É</b>	<b>À</b>	<b>È</b>	<b>ô</b>	<b>ö</b>	<b>ò</b>	<b>Ú</b>	<b>ù</b>	<b>ì</b>	<b>Õ</b>	<b>Ü</b>	<b>ç</b>	<b>£</b>	<b>Ù</b>	<b>Þ</b>	<b>Ó</b>
Hex	0090	0091	0092	0093	0094	0095	0096	0097	0098	0099	009A	009B	009C	009D	009E	009F
Dec	144	145	146	147	148	149	150	151	152	153	154	155	156	157	158	159
Char	<b>á</b>	<b>í</b>	<b>ó</b>	<b>ú</b>	<b>ñ</b>	<b>Ñ</b>	<b>a</b>	<b>o</b>	<b>ç</b>	<b>Ò</b>	<b>¬</b>	<b>½</b>	<b>¼</b>	<b>i</b>	<b>«</b>	<b>»</b>
Hex	00A0	00A1	00A2	00A3	00A4	00A5	00A6	00A7	00A8	00A9	00AA	00AB	00AC	00AD	00AE	00AF
Dec	160	161	162	163	164	165	166	167	168	169	170	171	172	173	174	175
Char																
Hex	00B0	00B1	00B2	00B3	00B4	00B5	00B6	00B7	00B8	00B9	00BA	00BB	00BC	00BD	00BE	00BF
Dec	176	177	178	179	180	181	182	183	184	185	186	187	188	189	190	191
Char																
Hex	00C0	00C1	00C2	00C3	00C4	00C5	00C6	00C7	00C8	00C9	00CA	00CB	00CC	00CD	00CE	00CF
Dec	192	193	194	195	196	197	198	199	200	201	202	203	204	205	206	207
Char																
Hex	00D0	00D1	00D2	00D3	00D4	00D5	00D6	00D7	00D8	00D9	00DA	00DB	00DC	00DD	00DE	00DF
Dec	208	209	210	211	212	213	214	215	216	217	218	219	220	221	222	223
Char	<b>α</b>	<b>β</b>	<b>Γ</b>	<b>π</b>	<b>Σ</b>	<b>σ</b>	<b>μ</b>	<b>τ</b>	<b>Φ</b>	<b>Θ</b>	<b>Ω</b>	<b>δ</b>	<b>∞</b>	<b>φ</b>	<b>ε</b>	<b>∩</b>
Hex	00E0	00E1	00E2	00E3	00E4	00E5	00E6	00E7	00E8	00E9	00EA	00EB	00EC	00ED	00EE	00EF
Dec	224	225	226	227	228	229	230	231	232	233	234	235	236	237	238	239
Char	<b>≡</b>	<b>±</b>	<b>≥</b>	<b>≤</b>	<b>∫</b>	<b>∫</b>	<b>÷</b>	<b>≈</b>	<b>°</b>	<b>·</b>	<b>·</b>	<b>√</b>	<b>n</b>	<b>²</b>	<b>■</b>	<b>NBSP</b>
Hex	00F0	00F1	00F2	00F3	00F4	00F5	00F6	00F7	00F8	00F9	00FA	00FB	00FC	00FD	00FE	00FF
Dec	240	241	242	243	244	245	246	247	248	249	250	251	252	253	254	255

## 7. SPECIFICATIONS

PC863 CODE TABLE (Canadian, French)







Char	<b>SP</b>	<b>!</b>	<b>“</b>	<b>#</b>	<b>\$</b>	<b>%</b>	<b>&amp;</b>	<b>‘</b>	<b>(</b>	<b>)</b>	<b>*</b>	<b>+</b>	<b>,</b>	<b>-</b>	<b>.</b>	<b>/</b>
Hex	0020	0021	0022	0023	0024	0025	0026	0027	0028	0029	002A	002B	002C	002D	002E	002F
Dec	32	33	34	35	36	37	38	39	40	41	42	43	44	45	46	47
Char	<b>0</b>	<b>1</b>	<b>2</b>	<b>3</b>	<b>4</b>	<b>5</b>	<b>6</b>	<b>7</b>	<b>8</b>	<b>9</b>	<b>:</b>	<b>;</b>	<b>&lt;</b>	<b>=</b>	<b>&gt;</b>	<b>?</b>
Hex	0030	0031	0032	0033	0034	0035	0036	0037	0038	0039	003A	003B	003C	003D	003E	003F
Dec	48	49	50	51	52	53	54	55	56	57	58	59	60	61	62	63
Char	<b>@</b>	<b>A</b>	<b>B</b>	<b>C</b>	<b>D</b>	<b>E</b>	<b>F</b>	<b>G</b>	<b>H</b>	<b>I</b>	<b>J</b>	<b>K</b>	<b>L</b>	<b>M</b>	<b>N</b>	<b>O</b>
Hex	0040	0041	0042	0043	0044	0045	0046	0047	0048	0049	004A	004B	004C	004D	004E	004F
Dec	64	65	66	67	68	69	70	71	72	73	74	75	76	77	78	79
Char	<b>P</b>	<b>Q</b>	<b>R</b>	<b>S</b>	<b>T</b>	<b>U</b>	<b>V</b>	<b>W</b>	<b>X</b>	<b>Y</b>	<b>Z</b>	<b>[</b>	<b>\</b>	<b>]</b>	<b>^</b>	<b>_</b>
Hex	0050	0051	0052	0053	0054	0055	0056	0057	0058	0059	005A	005B	005C	005D	005E	005F
Dec	80	81	82	83	84	85	86	87	88	89	90	91	92	93	94	95
Char	<b>`</b>	<b>a</b>	<b>b</b>	<b>c</b>	<b>d</b>	<b>e</b>	<b>f</b>	<b>g</b>	<b>h</b>	<b>i</b>	<b>j</b>	<b>k</b>	<b>l</b>	<b>m</b>	<b>n</b>	<b>o</b>
Hex	0060	0061	0062	0063	0064	0065	0066	0067	0068	0069	006A	006B	006C	006D	006E	006F
Dec	96	97	98	99	100	101	102	103	104	105	106	107	108	109	110	111
Char	<b>p</b>	<b>q</b>	<b>r</b>	<b>s</b>	<b>t</b>	<b>u</b>	<b>v</b>	<b>w</b>	<b>x</b>	<b>y</b>	<b>z</b>	<b>{</b>	<b> </b>	<b>}</b>	<b>~</b>	<b>△</b>
Hex	0070	0071	0072	0073	0074	0075	0076	0077	0078	0079	007A	007B	007C	007D	007E	007F
Dec	112	113	114	115	116	117	118	119	120	121	122	123	124	125	126	127
Char	<b>Ç</b>	<b>ü</b>	<b>é</b>	<b>â</b>	<b>Â</b>	<b>à</b>	<b>ŕ</b>	<b>ç</b>	<b>ê</b>	<b>ë</b>	<b>è</b>	<b>ï</b>	<b>î</b>	<b>=</b>	<b>À</b>	<b>§</b>
Hex	0080	0081	0082	0083	0084	0085	0086	0087	0088	0089	008A	008B	008C	008D	008E	008F
Dec	128	129	130	131	132	133	134	135	136	137	138	139	140	141	142	143
Char	<b>É</b>	<b>È</b>	<b>Ê</b>	<b>ô</b>	<b>Ë</b>	<b>ï</b>	<b>û</b>	<b>ù</b>	<b>¤</b>	<b>Ô</b>	<b>Ü</b>	<b>¢</b>	<b>£</b>	<b>Ù</b>	<b>Û</b>	<b>f</b>
Hex	0090	0091	0092	0093	0094	0095	0096	0097	0098	0099	009A	009B	009C	009D	009E	009F
Dec	144	145	146	147	148	149	150	151	152	153	154	155	156	157	158	159
Char	<b>¡</b>	<b>´</b>	<b>ó</b>	<b>ú</b>	<b>¨</b>	<b>¸</b>	<b>³</b>	<b>—</b>	<b>î</b>	<b>ƒ</b>	<b>¬</b>	<b>½</b>	<b>¼</b>	<b>¾</b>	<b>«</b>	<b>»</b>
Hex	00A0	00A1	00A2	00A3	00A4	00A5	00A6	00A7	00A8	00A9	00AA	00AB	00AC	00AD	00AE	00AF
Dec	160	161	162	163	164	165	166	167	168	169	170	171	172	173	174	175
Char																
Hex	00B0	00B1	00B2	00B3	00B4	00B5	00B6	00B7	00B8	00B9	00BA	00BB	00BC	00BD	00BE	00BF
Dec	176	177	178	179	180	181	182	183	184	185	186	187	188	189	190	191
Char																
Hex	00C0	00C1	00C2	00C3	00C4	00C5	00C6	00C7	00C8	00C9	00CA	00CB	00CC	00CD	00CE	00CF
Dec	192	193	194	195	196	197	198	199	200	201	202	203	204	205	206	207
Char																
Hex	00D0	00D1	00D2	00D3	00D4	00D5	00D6	00D7	00D8	00D9	00DA	00DB	00DC	00DD	00DE	00DF
Dec	208	209	210	211	212	213	214	215	216	217	218	219	220	221	222	223
Char	<b>α</b>	<b>β</b>	<b>Γ</b>	<b>π</b>	<b>Σ</b>	<b>σ</b>	<b>μ</b>	<b>τ</b>	<b>Φ</b>	<b>Θ</b>	<b>Ω</b>	<b>δ</b>	<b>∞</b>	<b>φ</b>	<b>ε</b>	<b>∩</b>
Hex	00E0	00E1	00E2	00E3	00E4	00E5	00E6	00E7	00E8	00E9	00EA	00EB	00EC	00ED	00EE	00EF
Dec	224	225	226	227	228	229	230	231	232	233	234	235	236	237	238	239
Char	<b>≡</b>	<b>±</b>	<b>≥</b>	<b>≤</b>	<b>∫</b>	<b>∫</b>	<b>÷</b>	<b>≈</b>	<b>°</b>	<b>·</b>	<b>·</b>	<b>√</b>	<b>n</b>	<b>²</b>	<b>■</b>	<b>NBSP</b>
Hex	00F0	00F1	00F2	00F3	00F4	00F5	00F6	00F7	00F8	00F9	00FA	00FB	00FC	00FD	00FE	00FF
Dec	240	241	242	243	244	245	246	247	248	249	250	251	252	253	254	255

PC865 CODE TABLE (Nordic)

Char	<b>SP</b>	<b>!</b>	<b>“</b>	<b>#</b>	<b>\$</b>	<b>%</b>	<b>&amp;</b>	<b>‘</b>	<b>(</b>	<b>)</b>	<b>*</b>	<b>+</b>	<b>,</b>	<b>-</b>	<b>.</b>	<b>/</b>	
Hex	0020	0021	0022	0023	0024	0025	0026	0027	0028	0029	002A	002B	002C	002D	002E	002F	
Dec	32	33	34	35	36	37	38	39	40	41	42	43	44	45	46	47	
Char	<b>0</b>	<b>1</b>	<b>2</b>	<b>3</b>	<b>4</b>	<b>5</b>	<b>6</b>	<b>7</b>	<b>8</b>	<b>9</b>	<b>:</b>	<b>;</b>	<b>&lt;</b>	<b>=</b>	<b>&gt;</b>	<b>?</b>	
Hex	0030	0031	0032	0033	0034	0035	0036	0037	0038	0039	003A	003B	003C	003D	003E	003F	
Dec	48	49	50	51	52	53	54	55	56	57	58	59	60	61	62	63	
Char	<b>@</b>	<b>A</b>	<b>B</b>	<b>C</b>	<b>D</b>	<b>E</b>	<b>F</b>	<b>G</b>	<b>H</b>	<b>I</b>	<b>J</b>	<b>K</b>	<b>L</b>	<b>M</b>	<b>N</b>	<b>O</b>	
Hex	0040	0041	0042	0043	0044	0045	0046	0047	0048	0049	004A	004B	004C	004D	004E	004F	
Dec	64	65	66	67	68	69	70	71	72	73	74	75	76	77	78	79	
Char	<b>P</b>	<b>Q</b>	<b>R</b>	<b>S</b>	<b>T</b>	<b>U</b>	<b>V</b>	<b>W</b>	<b>X</b>	<b>Y</b>	<b>Z</b>	<b>[</b>	<b>\</b>	<b>]</b>	<b>^</b>	<b>_</b>	
Hex	0050	0051	0052	0053	0054	0055	0056	0057	0058	0059	005A	005B	005C	005D	005E	005F	
Dec	80	81	82	83	84	85	86	87	88	89	90	91	92	93	94	95	
Char	<b>`</b>	<b>a</b>	<b>b</b>	<b>c</b>	<b>d</b>	<b>e</b>	<b>f</b>	<b>g</b>	<b>h</b>	<b>i</b>	<b>j</b>	<b>k</b>	<b>l</b>	<b>m</b>	<b>n</b>	<b>o</b>	
Hex	0060	0061	0062	0063	0064	0065	0066	0067	0068	0069	006A	006B	006C	006D	006E	006F	
Dec	96	97	98	99	100	101	102	103	104	105	106	107	108	109	110	111	
Char	<b>p</b>	<b>q</b>	<b>r</b>	<b>s</b>	<b>t</b>	<b>u</b>	<b>v</b>	<b>w</b>	<b>x</b>	<b>y</b>	<b>z</b>	<b>{</b>	<b> </b>	<b>}</b>	<b>~</b>	<b>␣</b>	
Hex	0070	0071	0072	0073	0074	0075	0076	0077	0078	0079	007A	007B	007C	007D	007E	007F	
Dec	112	113	114	115	116	117	118	119	120	121	122	123	124	125	126	127	
Char	<b>Ç</b>	<b>ü</b>	<b>é</b>	<b>â</b>	<b>ä</b>	<b>à</b>	<b>å</b>	<b>ç</b>	<b>ê</b>	<b>ë</b>	<b>è</b>	<b>ï</b>	<b>î</b>	<b>ì</b>	<b>Ä</b>	<b>Å</b>	
Hex	0080	0081	0082	0083	0084	0085	0086	0087	0088	0089	008A	008B	008C	008D	008E	008F	
Dec	128	129	130	131	132	133	134	135	136	137	138	139	140	141	142	143	
Char	<b>É</b>	<b>æ</b>	<b>Æ</b>	<b>ô</b>	<b>ö</b>	<b>ò</b>	<b>û</b>	<b>ù</b>	<b>ÿ</b>	<b>Ö</b>	<b>Ü</b>	<b>ø</b>	<b>£</b>	<b>Ø</b>	<b>Þ</b>	<b>ƒ</b>	
Hex	0090	0091	0092	0093	0094	0095	0096	0097	0098	0099	009A	009B	009C	009D	009E	009F	
Dec	144	145	146	147	148	149	150	151	152	153	154	155	156	157	158	159	
Char	<b>á</b>	<b>í</b>	<b>ó</b>	<b>ú</b>	<b>ñ</b>	<b>Ñ</b>	<b>ª</b>	<b>º</b>	<b>¿</b>	<b>¬</b>	<b>½</b>	<b>¼</b>	<b>¡</b>	<b>«</b>	<b>»</b>		
Hex	00A0	00A1	00A2	00A3	00A4	00A5	00A6	00A7	00A8	00A9	00AA	00AB	00AC	00AD	00AE	00AF	
Dec	160	161	162	163	164	165	166	167	168	169	170	171	172	173	174	175	
Char																	
Hex	00B0	00B1	00B2	00B3	00B4	00B5	00B6	00B7	00B8	00B9	00BA	00BB	00BC	00BD	00BE	00BF	
Dec	176	177	178	179	180	181	182	183	184	185	186	187	188	189	190	191	
Char																	
Hex	00C0	00C1	00C2	00C3	00C4	00C5	00C6	00C7	00C8	00C9	00CA	00CB	00CC	00CD	00CE	00CF	
Dec	192	193	194	195	196	197	198	199	200	201	202	203	204	205	206	207	
Char																	
Hex	00D0	00D1	00D2	00D3	00D4	00D5	00D6	00D7	00D8	00D9	00DA	00DB	00DC	00DD	00DE	00DF	
Dec	208	209	210	211	212	213	214	215	216	217	218	219	220	221	222	223	
Char	<b>α</b>	<b>β</b>	<b>Γ</b>	<b>π</b>	<b>Σ</b>	<b>σ</b>	<b>μ</b>	<b>τ</b>	<b>Φ</b>	<b>Θ</b>	<b>Ω</b>	<b>δ</b>	<b>∞</b>	<b>φ</b>	<b>ε</b>	<b>∩</b>	
Hex	00E0	00E1	00E2	00E3	00E4	00E5	00E6	00E7	00E8	00E9	00EA	00EB	00EC	00ED	00EE	00EF	
Dec	224	225	226	227	228	229	230	231	232	233	234	235	236	237	238	239	
Char	<b>≡</b>	<b>±</b>	<b>≥</b>	<b>≤</b>	<b>∫</b>	<b>∫</b>	<b>÷</b>	<b>≈</b>	<b>°</b>	<b>·</b>	<b>·</b>	<b>√</b>	<b>n</b>	<b>²</b>	<b>■</b>	<b>NBSP</b>	
Hex	00F0	00F1	00F2	00F3	00F4	00F5	00F6	00F7	00F8	00F9	00FA	00FB	00FC	00FD	00FE	00FF	
Dec	240	241	242	243	244	245	246	247	248	249	250	251	252	253	254	255	

## 7. SPECIFICATIONS

PC858 CODE TABLE (Euro symbol)

Char	<b>SP</b>	<b>!</b>	<b>“</b>	<b>#</b>	<b>\$</b>	<b>%</b>	<b>&amp;</b>	<b>‘</b>	<b>(</b>	<b>)</b>	<b>*</b>	<b>+</b>	<b>,</b>	<b>-</b>	<b>.</b>	<b>/</b>	
Hex	0020	0021	0022	0023	0024	0025	0026	0027	0028	0029	002A	002B	002C	002D	002E	002F	
Dec	32	33	34	35	36	37	38	39	40	41	42	43	44	45	46	47	
Char	<b>0</b>	<b>1</b>	<b>2</b>	<b>3</b>	<b>4</b>	<b>5</b>	<b>6</b>	<b>7</b>	<b>8</b>	<b>9</b>	<b>:</b>	<b>;</b>	<b>&lt;</b>	<b>=</b>	<b>&gt;</b>	<b>?</b>	
Hex	0030	0031	0032	0033	0034	0035	0036	0037	0038	0039	003A	003B	003C	003D	003E	003F	
Dec	48	49	50	51	52	53	54	55	56	57	58	59	60	61	62	63	
Char	<b>@</b>	<b>A</b>	<b>B</b>	<b>C</b>	<b>D</b>	<b>E</b>	<b>F</b>	<b>G</b>	<b>H</b>	<b>I</b>	<b>J</b>	<b>K</b>	<b>L</b>	<b>M</b>	<b>N</b>	<b>O</b>	
Hex	0040	0041	0042	0043	0044	0045	0046	0047	0048	0049	004A	004B	004C	004D	004E	004F	
Dec	64	65	66	67	68	69	70	71	72	73	74	75	76	77	78	79	
Char	<b>P</b>	<b>Q</b>	<b>R</b>	<b>S</b>	<b>T</b>	<b>U</b>	<b>V</b>	<b>W</b>	<b>X</b>	<b>Y</b>	<b>Z</b>	<b>[</b>	<b>\</b>	<b>]</b>	<b>^</b>	<b>_</b>	
Hex	0050	0051	0052	0053	0054	0055	0056	0057	0058	0059	005A	005B	005C	005D	005E	005F	
Dec	80	81	82	83	84	85	86	87	88	89	90	91	92	93	94	95	
Char	<b>`</b>	<b>a</b>	<b>b</b>	<b>c</b>	<b>d</b>	<b>e</b>	<b>f</b>	<b>g</b>	<b>h</b>	<b>i</b>	<b>j</b>	<b>k</b>	<b>l</b>	<b>m</b>	<b>n</b>	<b>o</b>	
Hex	0060	0061	0062	0063	0064	0065	0066	0067	0068	0069	006A	006B	006C	006D	006E	006F	
Dec	96	97	98	99	100	101	102	103	104	105	106	107	108	109	110	111	
Char	<b>p</b>	<b>q</b>	<b>r</b>	<b>s</b>	<b>t</b>	<b>u</b>	<b>v</b>	<b>w</b>	<b>x</b>	<b>y</b>	<b>z</b>	<b>{</b>	<b> </b>	<b>}</b>	<b>~</b>	<b>△</b>	
Hex	0070	0071	0072	0073	0074	0075	0076	0077	0078	0079	007A	007B	007C	007D	007E	007F	
Dec	112	113	114	115	116	117	118	119	120	121	122	123	124	125	126	127	
Char	<b>Ç</b>	<b>ü</b>	<b>é</b>	<b>â</b>	<b>ä</b>	<b>à</b>	<b>å</b>	<b>ç</b>	<b>ê</b>	<b>ë</b>	<b>è</b>	<b>ï</b>	<b>î</b>	<b>ì</b>	<b>Ä</b>	<b>Å</b>	
Hex	0080	0081	0082	0083	0084	0085	0086	0087	0088	0089	008A	008B	008C	008D	008E	008F	
Dec	128	129	130	131	132	133	134	135	136	137	138	139	140	141	142	143	
Char	<b>É</b>	<b>æ</b>	<b>Æ</b>	<b>ô</b>	<b>ö</b>	<b>ò</b>	<b>û</b>	<b>ù</b>	<b>ÿ</b>	<b>Ö</b>	<b>Ü</b>	<b>ø</b>	<b>£</b>	<b>Ø</b>	<b>×</b>	<b>f</b>	
Hex	0090	0091	0092	0093	0094	0095	0096	0097	0098	0099	009A	009B	009C	009D	009E	009F	
Dec	144	145	146	147	148	149	150	151	152	153	154	155	156	157	158	159	
Char	<b>á</b>	<b>í</b>	<b>ó</b>	<b>ú</b>	<b>ñ</b>	<b>Ñ</b>	<b>ª</b>	<b>º</b>	<b>¿</b>	<b>®</b>	<b>¬</b>	<b>½</b>	<b>¼</b>	<b>¡</b>	<b>«</b>	<b>»</b>	
Hex	00A0	00A1	00A2	00A3	00A4	00A5	00A6	00A7	00A8	00A9	00AA	00AB	00AC	00AD	00AE	00AF	
Dec	160	161	162	163	164	165	166	167	168	169	170	171	172	173	174	175	
Char				<b> </b>	<b>†</b>	<b>Á</b>	<b>Â</b>	<b>À</b>	<b>©</b>	<b>‡</b>	<b>¶</b>	<b>¶</b>	<b>¶</b>	<b>¶</b>	<b>¢</b>	<b>¥</b>	<b>¬</b>
Hex	00B0	00B1	00B2	00B3	00B4	00B5	00B6	00B7	00B8	00B9	00BA	00BB	00BC	00BD	00BE	00BF	
Dec	176	177	178	179	180	181	182	183	184	185	186	187	188	189	190	191	
Char	<b>L</b>	<b>⊥</b>	<b>T</b>	<b>†</b>	<b>—</b>	<b>†</b>	<b>ã</b>	<b>Ã</b>	<b>ℓ</b>	<b>ℓ</b>	<b>ℓ</b>	<b>ℓ</b>	<b>ℓ</b>	<b>ℓ</b>	<b>=</b>	<b>‡</b>	<b>¤</b>
Hex	00C0	00C1	00C2	00C3	00C4	00C5	00C6	00C7	00C8	00C9	00CA	00CB	00CC	00CD	00CE	00CF	
Dec	192	193	194	195	196	197	198	199	200	201	202	203	204	205	206	207	
Char	<b>ø</b>	<b>Ð</b>	<b>Ê</b>	<b>Ë</b>	<b>È</b>	<b>€</b>	<b>Í</b>	<b>Î</b>	<b>Ï</b>	<b>⌋</b>	<b>⌈</b>			<b>¡</b>	<b>ì</b>		
Hex	00D0	00D1	00D2	00D3	00D4	00D5	00D6	00D7	00D8	00D9	00DA	00DB	00DC	00DD	00DE	00DF	
Dec	208	209	210	211	212	213	214	215	216	217	218	219	220	221	222	223	
Char	<b>Ó</b>	<b>ß</b>	<b>Ô</b>	<b>Ò</b>	<b>õ</b>	<b>Õ</b>	<b>µ</b>	<b>þ</b>	<b>Þ</b>	<b>Ú</b>	<b>Û</b>	<b>Ù</b>	<b>ý</b>	<b>Ý</b>	<b>¯</b>	<b>´</b>	
Hex	00E0	00E1	00E2	00E3	00E4	00E5	00E6	00E7	00E8	00E9	00EA	00EB	00EC	00ED	00EE	00EF	
Dec	224	225	226	227	228	229	230	231	232	233	234	235	236	237	238	239	
Char	<b>SHY</b>	<b>±</b>	<b>=</b>	<b>¾</b>	<b>¶</b>	<b>§</b>	<b>÷</b>	<b>˘</b>	<b>°</b>	<b>¨</b>	<b>·</b>	<b>1</b>	<b>3</b>	<b>2</b>		<b>NBSP</b>	
Hex	00F0	00F1	00F2	00F3	00F4	00F5	00F6	00F7	00F8	00F9	00FA	00FB	00FC	00FD	00FE	00FF	
Dec	240	241	242	243	244	245	246	247	248	249	250	251	252	253	254	255	

**NOTE:** To print the Euro (€) symbol, the command sequence is: \$1B, \$74, \$13, \$D5 (see Commands Manual).

PC866 CODE TABLE (Cyrillic)

Char	<b>SP</b>	<b>!</b>	<b>“</b>	<b>#</b>	<b>\$</b>	<b>%</b>	<b>&amp;</b>	<b>‘</b>	<b>(</b>	<b>)</b>	<b>*</b>	<b>+</b>	<b>,</b>	<b>-</b>	<b>.</b>	<b>/</b>
Hex	0020	0021	0022	0023	0024	0025	0026	0027	0028	0029	002A	002B	002C	002D	002E	002F
Dec	32	33	34	35	36	37	38	39	40	41	42	43	44	45	46	47
Char	<b>0</b>	<b>1</b>	<b>2</b>	<b>3</b>	<b>4</b>	<b>5</b>	<b>6</b>	<b>7</b>	<b>8</b>	<b>9</b>	<b>:</b>	<b>;</b>	<b>&lt;</b>	<b>=</b>	<b>&gt;</b>	<b>?</b>
Hex	0030	0031	0032	0033	0034	0035	0036	0037	0038	0039	003A	003B	003C	003D	003E	003F
Dec	48	49	50	51	52	53	54	55	56	57	58	59	60	61	62	63
Char	<b>@</b>	<b>A</b>	<b>B</b>	<b>C</b>	<b>D</b>	<b>E</b>	<b>F</b>	<b>G</b>	<b>H</b>	<b>I</b>	<b>J</b>	<b>K</b>	<b>L</b>	<b>M</b>	<b>N</b>	<b>O</b>
Hex	0040	0041	0042	0043	0044	0045	0046	0047	0048	0049	004A	004B	004C	004D	004E	004F
Dec	64	65	66	67	68	69	70	71	72	73	74	75	76	77	78	79
Char	<b>P</b>	<b>Q</b>	<b>R</b>	<b>S</b>	<b>T</b>	<b>U</b>	<b>V</b>	<b>W</b>	<b>X</b>	<b>Y</b>	<b>Z</b>	<b>[</b>	<b>\</b>	<b>]</b>	<b>^</b>	<b>_</b>
Hex	0050	0051	0052	0053	0054	0055	0056	0057	0058	0059	005A	005B	005C	005D	005E	005F
Dec	80	81	82	83	84	85	86	87	88	89	90	91	92	93	94	95
Char	<b>`</b>	<b>a</b>	<b>b</b>	<b>c</b>	<b>d</b>	<b>e</b>	<b>f</b>	<b>g</b>	<b>h</b>	<b>i</b>	<b>j</b>	<b>k</b>	<b>l</b>	<b>m</b>	<b>n</b>	<b>o</b>
Hex	0060	0061	0062	0063	0064	0065	0066	0067	0068	0069	006A	006B	006C	006D	006E	006F
Dec	96	97	98	99	100	101	102	103	104	105	106	107	108	109	110	111
Char	<b>p</b>	<b>q</b>	<b>r</b>	<b>s</b>	<b>t</b>	<b>u</b>	<b>v</b>	<b>w</b>	<b>x</b>	<b>y</b>	<b>z</b>	<b>{</b>	<b> </b>	<b>}</b>	<b>~</b>	<b>␣</b>
Hex	0070	0071	0072	0073	0074	0075	0076	0077	0078	0079	007A	007B	007C	007D	007E	007F
Dec	112	113	114	115	116	117	118	119	120	121	122	123	124	125	126	127
Char	<b>А</b>	<b>Б</b>	<b>В</b>	<b>Г</b>	<b>Д</b>	<b>Е</b>	<b>Ж</b>	<b>З</b>	<b>И</b>	<b>Й</b>	<b>К</b>	<b>Л</b>	<b>М</b>	<b>Н</b>	<b>О</b>	<b>П</b>
Hex	0080	0081	0082	0083	0084	0085	0086	0087	0088	0089	008A	008B	008C	008D	008E	008F
Dec	128	129	130	131	132	133	134	135	136	137	138	139	140	141	142	143
Char	<b>Р</b>	<b>С</b>	<b>Т</b>	<b>У</b>	<b>Ф</b>	<b>Х</b>	<b>Ц</b>	<b>Ч</b>	<b>Ш</b>	<b>Щ</b>	<b>Ъ</b>	<b>Ы</b>	<b>Ь</b>	<b>Э</b>	<b>Ю</b>	<b>Я</b>
Hex	0090	0091	0092	0093	0094	0095	0096	0097	0098	0099	009A	009B	009C	009D	009E	009F
Dec	144	145	146	147	148	149	150	151	152	153	154	155	156	157	158	159
Char	<b>а</b>	<b>б</b>	<b>в</b>	<b>г</b>	<b>д</b>	<b>е</b>	<b>ж</b>	<b>з</b>	<b>и</b>	<b>й</b>	<b>к</b>	<b>л</b>	<b>м</b>	<b>н</b>	<b>о</b>	<b>п</b>
Hex	00A0	00A1	00A2	00A3	00A4	00A5	00A6	00A7	00A8	00A9	00AA	00AB	00AC	00AD	00AE	00AF
Dec	160	161	162	163	164	165	166	167	168	169	170	171	172	173	174	175
Char																
Hex	00B0	00B1	00B2	00B3	00B4	00B5	00B6	00B7	00B8	00B9	00BA	00BB	00BC	00BD	00BE	00BF
Dec	176	177	178	179	180	181	182	183	184	185	186	187	188	189	190	191
Char																
Hex	00C0	00C1	00C2	00C3	00C4	00C5	00C6	00C7	00C8	00C9	00CA	00CB	00CC	00CD	00CE	00CF
Dec	192	193	194	195	196	197	198	199	200	201	202	203	204	205	206	207
Char																
Hex	00D0	00D1	00D2	00D3	00D4	00D5	00D6	00D7	00D8	00D9	00DA	00DB	00DC	00DD	00DE	00DF
Dec	208	209	210	211	212	213	214	215	216	217	218	219	220	221	222	223
Char	<b>р</b>	<b>с</b>	<b>т</b>	<b>у</b>	<b>ф</b>	<b>х</b>	<b>ц</b>	<b>ч</b>	<b>ш</b>	<b>щ</b>	<b>ъ</b>	<b>ы</b>	<b>ь</b>	<b>э</b>	<b>ю</b>	<b>я</b>
Hex	00E0	00E1	00E2	00E3	00E4	00E5	00E6	00E7	00E8	00E9	00EA	00EB	00EC	00ED	00EE	00EF
Dec	224	225	226	227	228	229	230	231	232	233	234	235	236	237	238	239
Char	<b>Ё</b>	<b>ё</b>	<b>Є</b>	<b>є</b>	<b>İ</b>	<b>і</b>	<b>Ў</b>	<b>ў</b>	<b>°</b>	<b>·</b>	<b>·</b>					<b>NBSP</b>
Hex	00F0	00F1	00F2	00F3	00F4	00F5	00F6	00F7	00F8	00F9	00FA	00FB	00FC	00FD	00FE	00FF
Dec	240	241	242	243	244	245	246	247	248	249	250	251	252	253	254	255

## 7. SPECIFICATIONS

VISCII CODE TABLE (Vietnamese standard code)

Char	<b>NUL</b>	<b>SOH</b>	<b>À</b>	<b>ETX</b>	<b>EOT</b>	<b>Ã</b>	<b>Ä</b>	<b>BEL</b>	<b>BS</b>	<b>HT</b>	<b>LF</b>	<b>VT</b>	<b>FF</b>	<b>CR</b>	<b>SO</b>	<b>SI</b>
Hex	0000	0001	0002	0003	0004	0005	0006	0007	0008	0009	000A	000B	000C	000D	000E	000F
Dec	0	1	2	3	4	5	6	7	8	9	10	11	12	13	14	15
Char	<b>DLE</b>	<b>DC1</b>	<b>DC2</b>	<b>DC3</b>	<b>ÿ</b>	<b>NAK</b>	<b>SYN</b>	<b>ETB</b>	<b>CAN</b>	<b>ÿ</b>	<b>SUB</b>	<b>ESC</b>	<b>FS</b>	<b>GS</b>	<b>ÿ</b>	<b>US</b>
Hex	0010	0011	0012	0013	0014	0015	0016	0017	0018	0019	001A	001B	001C	001D	001E	001F
Dec	16	17	18	19	20	21	22	23	24	25	26	27	28	29	30	31
Char	<b>SP</b>	<b>!</b>	<b>“</b>	<b>#</b>	<b>\$</b>	<b>%</b>	<b>&amp;</b>	<b>‘</b>	<b>(</b>	<b>)</b>	<b>*</b>	<b>+</b>	<b>,</b>	<b>-</b>	<b>.</b>	<b>/</b>
Hex	0020	0021	0022	0023	0024	0025	0026	0027	0028	0029	002A	002B	002C	002D	002E	002F
Dec	32	33	34	35	36	37	38	39	40	41	42	43	44	45	46	47
Char	<b>0</b>	<b>1</b>	<b>2</b>	<b>3</b>	<b>4</b>	<b>5</b>	<b>6</b>	<b>7</b>	<b>8</b>	<b>9</b>	<b>:</b>	<b>;</b>	<b>&lt;</b>	<b>=</b>	<b>&gt;</b>	<b>?</b>
Hex	0030	0031	0032	0033	0034	0035	0036	0037	0038	0039	003A	003B	003C	003D	003E	003F
Dec	48	49	50	51	52	53	54	55	56	57	58	59	60	61	62	63
Char	<b>@</b>	<b>A</b>	<b>B</b>	<b>C</b>	<b>D</b>	<b>E</b>	<b>F</b>	<b>G</b>	<b>H</b>	<b>I</b>	<b>J</b>	<b>K</b>	<b>L</b>	<b>M</b>	<b>N</b>	<b>O</b>
Hex	0040	0041	0042	0043	0044	0045	0046	0047	0048	0049	004A	004B	004C	004D	004E	004F
Dec	64	65	66	67	68	69	70	71	72	73	74	75	76	77	78	79
Char	<b>P</b>	<b>Q</b>	<b>R</b>	<b>S</b>	<b>T</b>	<b>U</b>	<b>V</b>	<b>W</b>	<b>X</b>	<b>Y</b>	<b>Z</b>	<b>[</b>	<b>\</b>	<b>]</b>	<b>^</b>	<b>_</b>
Hex	0050	0051	0052	0053	0054	0055	0056	0057	0058	0059	005A	005B	005C	005D	005E	005F
Dec	80	81	82	83	84	85	86	87	88	89	90	91	92	93	94	95
Char	<b>`</b>	<b>a</b>	<b>b</b>	<b>c</b>	<b>d</b>	<b>e</b>	<b>f</b>	<b>g</b>	<b>h</b>	<b>i</b>	<b>j</b>	<b>k</b>	<b>l</b>	<b>m</b>	<b>n</b>	<b>o</b>
Hex	0060	0061	0062	0063	0064	0065	0066	0067	0068	0069	006A	006B	006C	006D	006E	006F
Dec	96	97	98	99	100	101	102	103	104	105	106	107	108	109	110	111
Char	<b>p</b>	<b>q</b>	<b>r</b>	<b>s</b>	<b>t</b>	<b>u</b>	<b>v</b>	<b>w</b>	<b>x</b>	<b>y</b>	<b>z</b>	<b>{</b>	<b> </b>	<b>}</b>	<b>~</b>	<b>DEL</b>
Hex	0070	0071	0072	0073	0074	0075	0076	0077	0078	0079	007A	007B	007C	007D	007E	007F
Dec	112	113	114	115	116	117	118	119	120	121	122	123	124	125	126	127
Char	<b>À</b>	<b>Á</b>	<b>Â</b>	<b>Ã</b>	<b>Ä</b>	<b>Å</b>	<b>Ä</b>	<b>Å</b>	<b>Ë</b>	<b>Ë</b>	<b>É</b>	<b>È</b>	<b>Ê</b>	<b>Ë</b>	<b>Ë</b>	<b>Ë</b>
Hex	0080	0081	0082	0083	0084	0085	0086	0087	0088	0089	008A	008B	008C	008D	008E	008F
Dec	128	129	130	131	132	133	134	135	136	137	138	139	140	141	142	143
Char	<b>Ò</b>	<b>Ó</b>	<b>Ô</b>	<b>Õ</b>	<b>Ö</b>	<b>Ï</b>	<b>Ð</b>	<b>Ñ</b>	<b>Ò</b>	<b>Ó</b>	<b>Ô</b>	<b>Õ</b>	<b>Ö</b>	<b>Ï</b>	<b>Ù</b>	<b>Ý</b>
Hex	0090	0091	0092	0093	0094	0095	0096	0097	0098	0099	009A	009B	009C	009D	009E	009F
Dec	144	145	146	147	148	149	150	151	152	153	154	155	156	157	158	159
Char	<b>Ö</b>	<b>á</b>	<b>â</b>	<b>ă</b>	<b>á</b>	<b>à</b>	<b>â</b>	<b>â</b>	<b>ë</b>	<b>ë</b>	<b>é</b>	<b>è</b>	<b>ê</b>	<b>ë</b>	<b>ê</b>	<b>ó</b>
Hex	00A0	00A1	00A2	00A3	00A4	00A5	00A6	00A7	00A8	00A9	00AA	00AB	00AC	00AD	00AE	00AF
Dec	160	161	162	163	164	165	166	167	168	169	170	171	172	173	174	175
Char	<b>ò</b>	<b>ó</b>	<b>ô</b>	<b>õ</b>	<b>ö</b>	<b>ï</b>	<b>ð</b>	<b>ñ</b>	<b>ò</b>	<b>ó</b>	<b>ô</b>	<b>õ</b>	<b>ö</b>	<b>ï</b>	<b>ù</b>	<b>ý</b>
Hex	00B0	00B1	00B2	00B3	00B4	00B5	00B6	00B7	00B8	00B9	00BA	00BB	00BC	00BD	00BE	00BF
Dec	176	177	178	179	180	181	182	183	184	185	186	187	188	189	190	191
Char	<b>À</b>	<b>Á</b>	<b>Â</b>	<b>Ã</b>	<b>Ä</b>	<b>Å</b>	<b>Ä</b>	<b>Å</b>	<b>È</b>	<b>É</b>	<b>Ê</b>	<b>Ë</b>	<b>Ì</b>	<b>Í</b>	<b>Î</b>	<b>ÿ</b>
Hex	00C0	00C1	00C2	00C3	00C4	00C5	00C6	00C7	00C8	00C9	00CA	00CB	00CC	00CD	00CE	00CF
Dec	192	193	194	195	196	197	198	199	200	201	202	203	204	205	206	207
Char	<b>Đ</b>	<b>ư</b>	<b>ò</b>	<b>ó</b>	<b>ô</b>	<b>ạ</b>	<b>ý</b>	<b>ừ</b>	<b>ử</b>	<b>ù</b>	<b>ú</b>	<b>ỹ</b>	<b>ỵ</b>	<b>Ý</b>	<b>ơ</b>	<b>ư</b>
Hex	00D0	00D1	00D2	00D3	00D4	00D5	00D6	00D7	00D8	00D9	00DA	00DB	00DC	00DD	00DE	00DF
Dec	208	209	210	211	212	213	214	215	216	217	218	219	220	221	222	223
Char	<b>à</b>	<b>á</b>	<b>â</b>	<b>ã</b>	<b>ä</b>	<b>å</b>	<b>ä</b>	<b>å</b>	<b>è</b>	<b>é</b>	<b>ê</b>	<b>ë</b>	<b>ì</b>	<b>í</b>	<b>î</b>	<b>ï</b>
Hex	00E0	00E1	00E2	00E3	00E4	00E5	00E6	00E7	00E8	00E9	00EA	00EB	00EC	00ED	00EE	00EF
Dec	224	225	226	227	228	229	230	231	232	233	234	235	236	237	238	239
Char	<b>đ</b>	<b>ư</b>	<b>ò</b>	<b>ó</b>	<b>ô</b>	<b>õ</b>	<b>ò</b>	<b>ọ</b>	<b>ụ</b>	<b>ù</b>	<b>ú</b>	<b>ũ</b>	<b>ủ</b>	<b>ý</b>	<b>ơ</b>	<b>ư</b>
Hex	00F0	00F1	00F2	00F3	00F4	00F5	00F6	00F7	00F8	00F9	00FA	00FB	00FC	00FD	00FE	00FF
Dec	240	241	242	243	244	245	246	247	248	249	250	251	252	253	254	255

## 8 CONSUMABLES

The following table shows the list of available consumables for device:

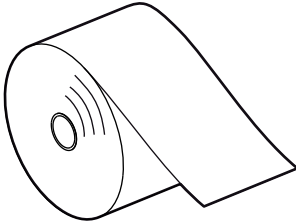

DESCRIPTION	CODE
<p>THERMAL PAPER ROLL</p> <p>width = 80mm Ø external = 90mm Ø core = 25mm</p>	<p><b>67300000000406</b></p> 



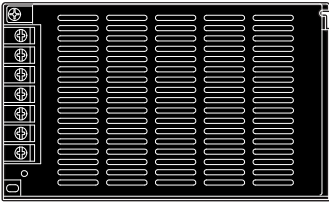

## 9 ACCESSORIES

The available accessories for the device are listed in the following table:

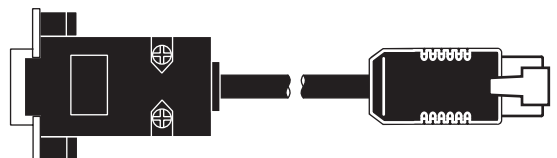
DESCRIPTION	CODE
<p>POWER SUPPLY 24V 100W (for technical specifications, see the paragraph 7.1)</p>	<p><b>964GE010000362</b></p> 
<p>USB cable A to B - 1,8 mt (WRDATI-USB-MM-AB-1.8-3)</p>	<p><b>26500000000356</b></p> 
<p>Serial cable RJ/DB9F - 1,5 mt (CB9POLI-PLUG8-03)</p>	<p><b>26500000000352</b></p> 



## 10 ALIGNMENT

The device is equipped with sensors that allow the use of paper with predetermined alignment, in order to handle rolls of tickets with pre-printed fields and a fixed length.

The notch alignment must be constituted by a black mark printed on paper (see par.7.7).

The alignment sensor mounted on the device is a “reflection” sensor: this kind of sensor emits a band of light and detects the quantity of light reflected to it. The presence of the notch is therefore detected by the amount of light that returns to the sensor, considering that the light is reflected by the white paper and absorbed by the black mark.

The following paragraphs show how to correctly set the configuration parameters of device in order to assure the alignment.

### 10.1 Enable alignment

To guarantee the alignment, it is necessary to enable the parameter “Notch Alignment” during the Setup procedure (see chapter 5).

### 10.2 Calibration

The sensor calibration occurs automatically and consists in adjusting the quantity of light emitted to match the degree of whiteness of the paper used and the degree of black of the mark printed on paper.

The device automatically performs the self-calibration during the Setup procedure only if the “Notch alignment” parameter is set to “Enabled” (see chapter 5).

When self-calibration starts, the device performs some paper feeds and then it prints the calibration result and the value of the PWM duty-cycle of the alignment sensor driver so that it can be perform an optimal notch detection:

Autosetting Notch : OK  
PWM Duty Cycle : 45%

The “Autosetting Notch” parameter indicates the result of the self-calibration procedure; OK will appear if it has been successful, NOT OK will appear if the procedure has failed.

After the printing of the procedure result, the device offers the execution of the function of paper characterization “Characterize Paper” and the change of the “Notch Threshold” parameter which represents the detection threshold of the notch.

Choosing the “Yes” value for the “Characterize Paper” parameter, the device prints a graphic representation (see following figures) of the outgoing voltage of the alignment sensor (expressed as a percentage) and the “Notch Threshold” value.

This graphic representation is useful to set the most suitable value to assign to the “Notch Threshold” parameter and then to better identify the optimal threshold value which takes into account the variations of the signal and the small oscillations around zero.

## 10. ALIGNMENT

The following figure shows an example of paper with the non-thermal paper printed with black marks: the outgoing voltage is constant while passing the white paper between two notches and presents a peak at each black mark. In this case, the optimal value for the “Notch Threshold” parameter is placed about half of the peak.

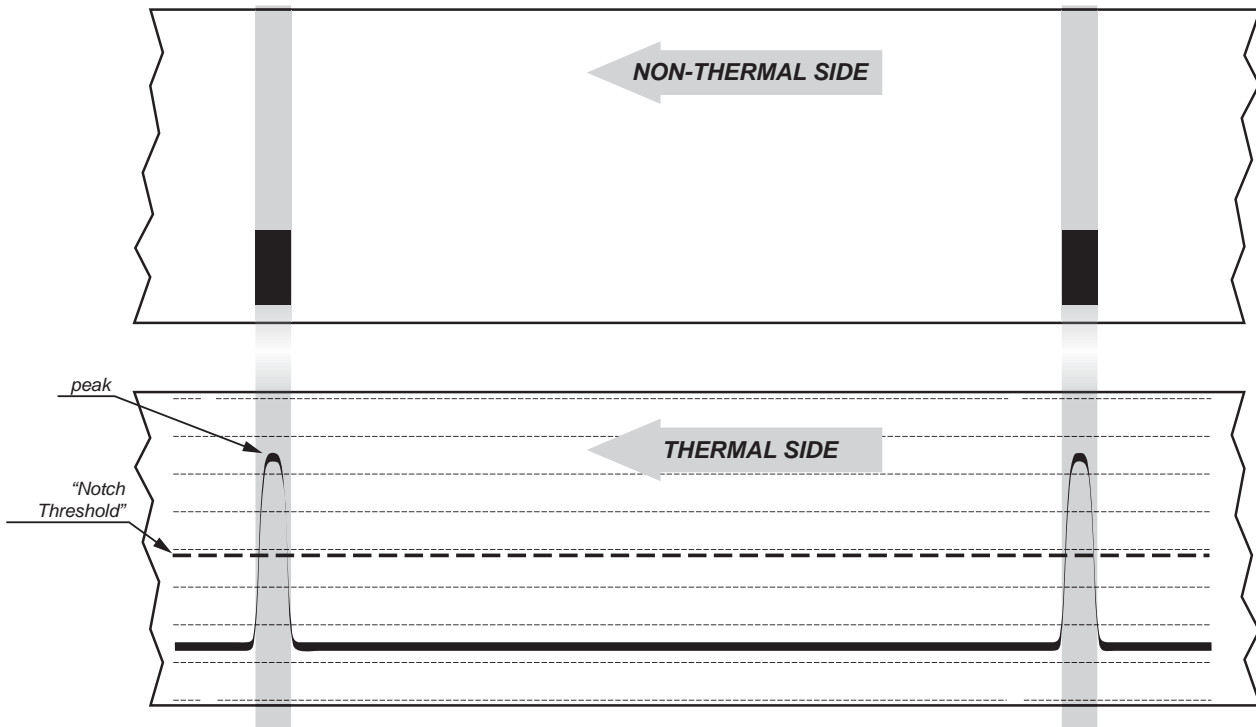

The following figure shows an example of paper with the non-thermal paper printed with black marks and other graphics (for example, a barcode): the outgoing voltage is constant while passing the white paper between two notches, presents a peak at each black mark and presents some “noise” at each barcode. In this case, the optimal value for the “Notch Threshold” parameter is located about halfway between the peak value and the maximum value of the “noise”.

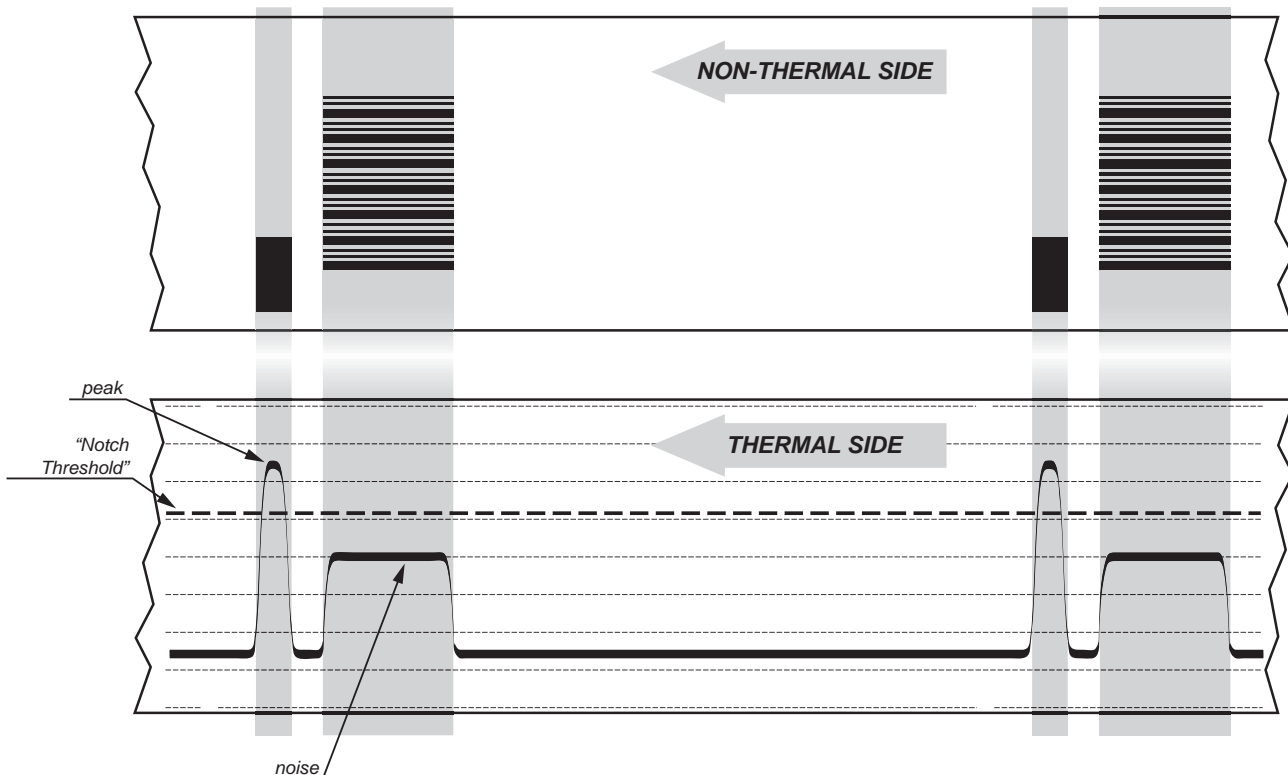

If the maximum value of “noise” read by the sensor is very close to the peak value, it might be difficult to place the value of the “Notch Threshold” at an intermediate point. In these cases, it is mandatory that the portion of paper between the point of printing end and the front notch is completely white (no graphics). In this way, the only next graphic detected by the sensor for alignment after the printing end will be the notch.

### 10.3 Alignment parameters

The “alignment point” is defined as the position inside the ticket to use for the notch alignment. The distance between the notch edge and the alignment point is defined as “Notch Distance”. If the “Notch Distance” value is set to 0, the alignment point is set at the beginning of the notch.

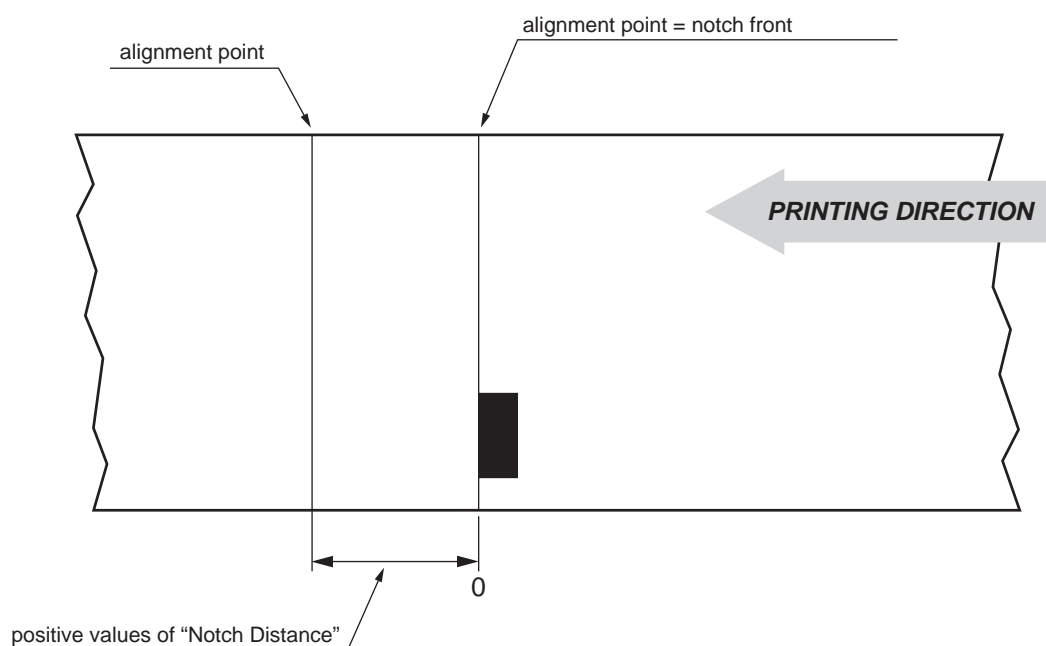

The “Notch Distance” value can have a minimum value of 0mm and a maximum of 12,9mm. This maximum value is imposed by the mechanical distance between the notch sensor and the printing head.

## 10. ALIGNMENT

The following figure shows a section of the device with the paper path and the distances (in mm) between the alignment sensors, the printing head and the cutter (cutting line).

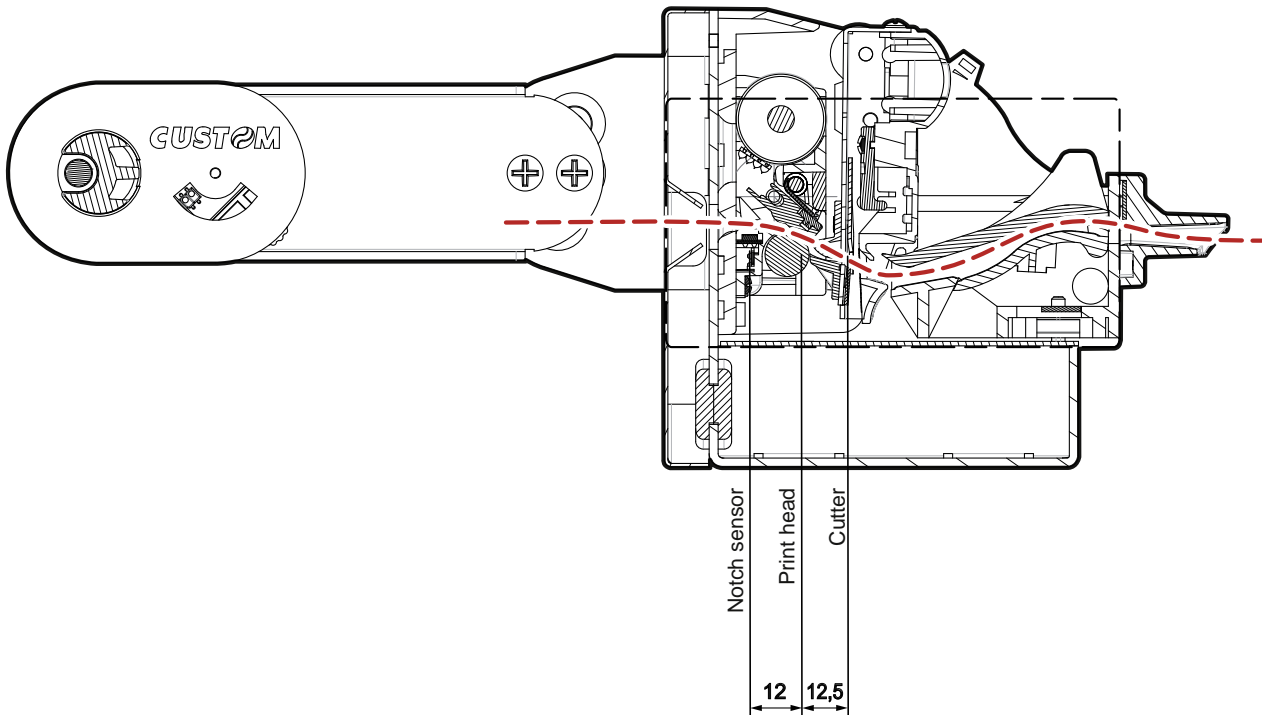

**ESC/POS™ EMULATION**

To define the alignment point you need to set the printer parameters that compose the numerical value of the “Notch Distance” parameter (see par.5.4).

For example, to set a notch distance of 10 mm between the notch and the alignment point, the parameters must be set on the following values:

*Notch Distance [mm x 10]* : 1  
*Notch Distance [mm x 1]* : 0  
*Notch Distance [mm x .1]* : 0

The “Notch Distance” parameter, may be modified as follows:

- during the Setup procedure of the device (see chapter 5)
- by using the \$1D \$E7 command (for more details, refer to the Commands Manual)
- by driver (facility tool).

### 10.4 Printing area

It is important to well calibrate the height of the printing area of ticket according to the inter-notch distance, in order to print ticket containing only one notch and to not overlay printing to a notch (that will make it useless for the next alignment).

The following figure shows an example of tickets with "Notch Distance" set to 0:

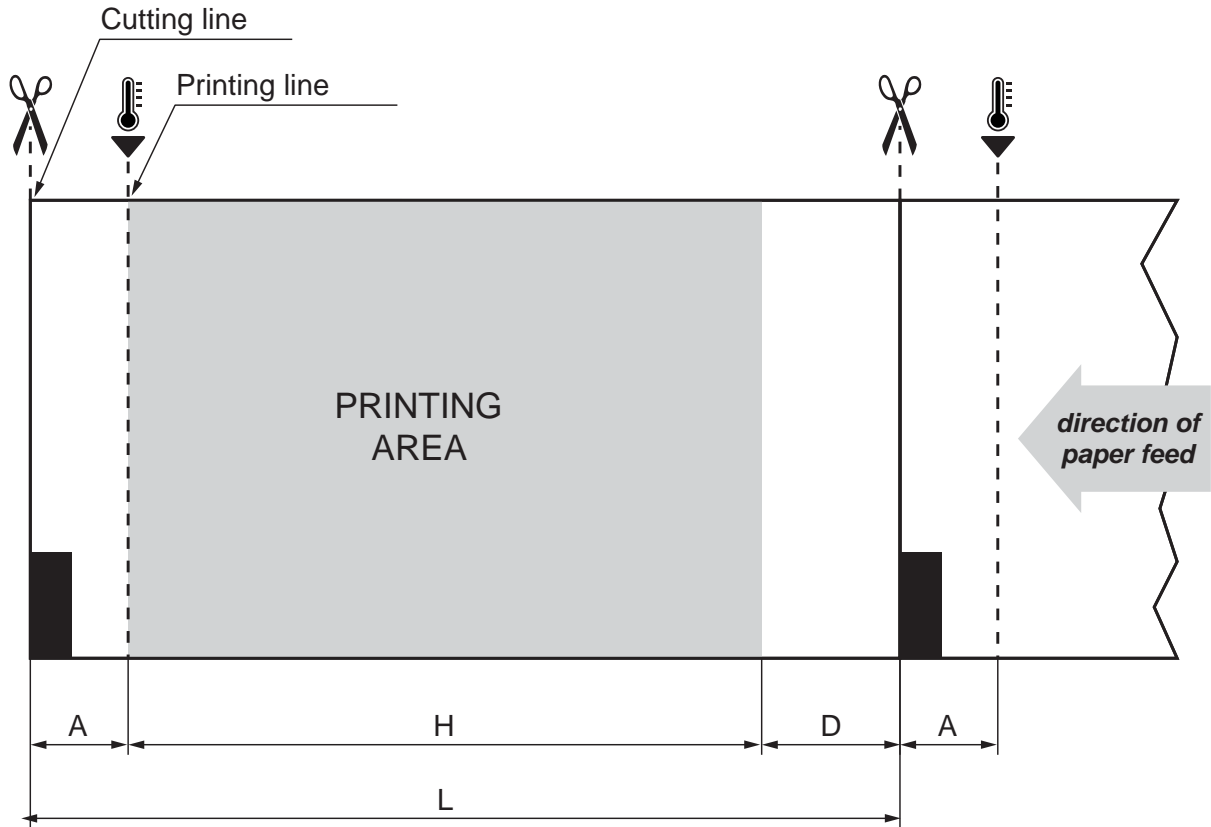

To use all the notches on the card, you must comply with the following equation:

$$L \geq H + A$$

where

L = INTER-NOTCH DISTANCE

A = NON-PRINTABLE AREA (12mm)

H = HEIGHT OF THE PRINTING AREA

The height of the printing area (H) can be increased to make no progress on alignment (D = 0) but no further.



## 11 TECHNICAL SERVICE

In case of failure, contact the Technical Service by sending an e-mail to [support@custom.it](mailto:support@custom.it) detailing:

1. Product code
2. Serial number
3. Hardware release
4. Firmware release

To get the necessary data, proceed as follows:

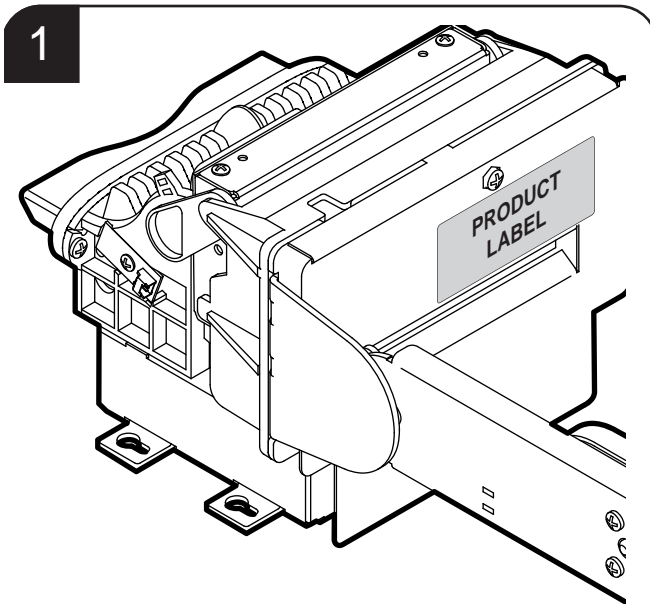

Find the product label located behind the printer.

2

**hardware release**

XXXXXXXXXXXXXXXX

XXXXXX XXX XXXX XXXX  
XXXXXX XXX XXXX XXXX

00000000000000000000

**serial number**

**product code (14 digits)**

The label shows the product code, serial number and hardware release.

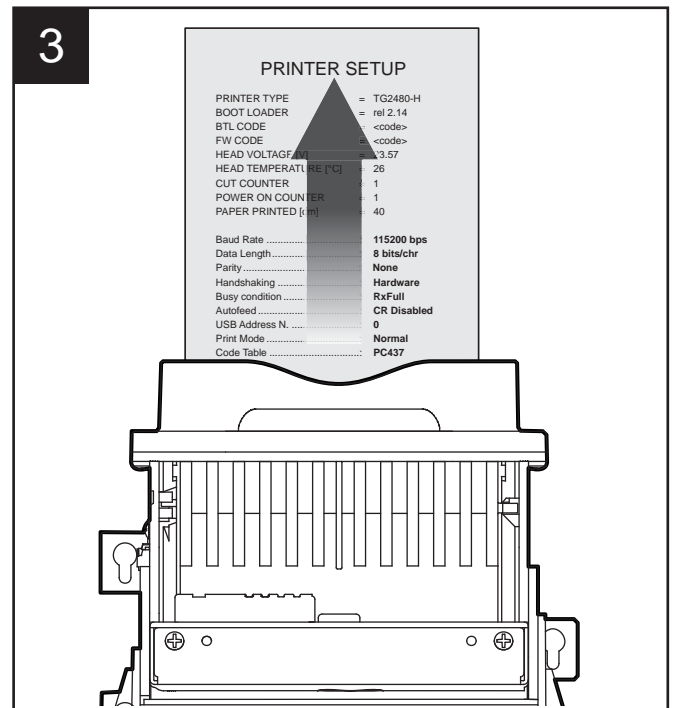

**PRINTER SETUP**

PRINTER TYPE = TG2480-H  
 BOOT LOADER = rel 2.14  
 BTL CODE = <code>  
 FW CODE = <code>  
 HEAD VOLTAGE [V] = 3.57  
 HEAD TEMPERATURE [°C] = 26  
 CUT COUNTER = 1  
 POWER ON COUNTER = 1  
 PAPER PRINTED [mm] = 40

Baud Rate ..... 115200 bps  
 Data Length ..... 8 bits/chr  
 Parity ..... None  
 Handshaking ..... Hardware  
 Busy condition ..... RxFull  
 Autofeed ..... CR Disabled  
 USB Address N ..... 0  
 Print Mode ..... Normal  
 Code Table ..... PC437

Print a Setup report (see paragraphs 5.2)

4

**firmware release**

TG2480-H rel 2.00

**PRINTER SETUP**

PRINTER TYPE = TG2480-H  
 BOOT LOADER = rel 2.14  
 BTL CODE = <code>  
 FW CODE = <code>  
 HEAD VOLTAGE [V] = 23,57

The Setup report shows the firmware release

5

**support@custom.it**  
 Customer Service Department

Send an e-mail to the Technical Service, with the data collected.





# CUSTOM



M . U . R . S . T .  
Ministry University  
Research Scientific  
T e c h n o l o g y  
Authorized laboratory  
n o . 5 0 8 4 6 Z Y Z

**CUSTOM ENGINEERING S.p.A.**

World Headquarters

**Via Berettine, 2 - 43010 Fontevivo, Parma ITALY**

**Tel. +39 0521 680111 - Fax +39 0521 610701**

**info@custom.biz - www.custom.biz**

*All rights reserved*